



cPCI-A3H20

3U CompactPCI® Serial
Storage Carrier Blade

User's Manual



Preliminary

Manual Rev.: 0.4 Preliminary
Revision Date: January 5, 2023
Part Number: 50M-00105-1000

Revision History

Revision	Release Date	Description of Change(s)
0.1	2022-12-12	Preliminary release
0.2	2022-12-16	Add installation info; clarifications
0.3	2022-12-23	Spec corrections/updates
0.4	2023-01-05	Spec updates

Preliminary

Preface

Copyright © 2022 ADLINK Technology, Inc.

This document contains proprietary information protected by copyright. All rights are reserved. No part of this manual may be reproduced by any mechanical, electronic, or other means in any form without prior written permission of the manufacturer.

Disclaimer

The information in this document is subject to change without prior notice in order to improve reliability, design, and function and does not represent a commitment on the part of the manufacturer.

In no event will the manufacturer be liable for direct, indirect, special, incidental, or consequential damages arising out of the use or inability to use the product or documentation, even if advised of the possibility of such damages.

Environmental Responsibility

ADLINK is committed to fulfill its social responsibility to global environmental preservation through compliance with the European Union's Restriction of Hazardous Substances (RoHS) directive and Waste Electrical and Electronic Equipment (WEEE) directive. Environmental protection is a top priority for ADLINK. We have enforced measures to ensure that our products, manufacturing processes, components, and raw materials have as little impact on the environment as possible. When products are at their end of life, our customers are encouraged to dispose of them in accordance with the product disposal and/or recovery programs prescribed by their nation or company.

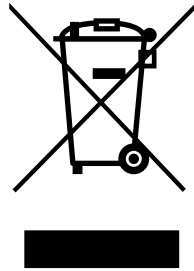

Battery Labels (for products with battery)



Li-ion



廢電池請回收

Preliminary

California Proposition 65 Warning



WARNING: This product can expose you to chemicals including acrylamide, arsenic, benzene, cadmium, Tris(1,3-dichloro-2-propyl)phosphate (TDCPP), 1,4-Dioxane, formaldehyde, lead, DEHP, styrene, DINP, BBP, PVC, and vinyl materials, which are known to the State of California to cause cancer, and acrylamide, benzene, cadmium, lead, mercury, phthalates, toluene, DEHP, DIDP, DnHP, DBP, BBP, PVC, and vinyl materials, which are known to the State of California to cause birth defects or other reproductive harm. For more information go to www.P65Warnings.ca.gov.

Trademarks

Product names mentioned herein are used for identification purposes only and may be trademarks and/or registered trademarks of their respective companies.

Conventions

Take note of the following conventions used throughout this manual to make sure that users perform certain tasks and instructions properly.



NOTE:

Additional information, aids, and tips that help users perform tasks.



CAUTION:

Information to prevent *minor* physical injury, component damage, data loss, and/or program corruption when trying to complete a task.



WARNING:

Information to prevent *serious* physical injury, component damage, data loss, and/or program corruption when trying to complete a specific task.

Table of Contents

Revision History	ii
Preface	iii
List of Figures	vii
List of Tables	ix
1 Introduction	1
1.1 Overview.....	1
1.2 Features.....	1
1.3 Contents	2
2 Specifications	3
2.1 cPCI-A3H20 Storage Carrier Blade Specifications.....	3
2.2 Block Diagrams.....	5
2.3 I/O Connectivity Table	6
3 Board Interfaces	7
3.1 cPCI-A3H20 Board Layout	7
3.2 cPCI-A3H20/P Assembly Layout	8
3.3 cPCI-A3H20/M Assembly Layout	8
3.4 cPCI-A3H20 Front Panel	9
3.5 Connector Pin Assignments	10
4 Getting Started	17
4.1 cPCI-A3H20/P	18
4.2 cPCI-A3H20/M.....	20
4.3 M.2 2242 Modules	21
Important Safety Instructions	23
Getting Service	25

Preliminary

This page intentionally left blank.

List of Figures

Figure 2-1: cPCI-A3H20 Functional Block Diagram.....	5
Figure 3-1: cPCI-A3H20 Board Layout	7
Figure 3-2: cPCI-A3H20/P Assembly Layout.....	8
Figure 3-3: cPCI-A3H20/M Assembly Layout	8
Figure 3-4: cPCI-A3H20 Front Panel Layout	9
Figure 3-5: CompactPCI Serial P1 Pin Definition Legend.....	16

Preliminary

This page intentionally left blank.

Preliminary

List of Tables

- Table 2-1: cPCI-A3H20 Storage Carrier Blade Specifications..... 3
- Table 2-2: cPCI-A3H20 I/O Connectivity 6
- Table 3-1: cPCI-A3H20 Front Panel Status LED Descriptions 9
- Table 3-2: U.2 NVMe Pin Definition 10
- Table 3-3: M.2 B-Key 2280 SATA Pin Definition 12
- Table 3-4: M.2 M-Key 2280 NVMe Pin Definition 14
- Table 3-5: CompactPCI Serial P1 Connector Pin Definition 16

Preliminary

This page intentionally left blank.

Preliminary

1 Introduction

1.1 Overview

The cPCI-A3H20 is a 3U 4HP CompactPCI Serial storage carrier blade compliant to the PICMG CompactPCI® Serial (CPCI-S.0) specification. Two configurations are available: the cPCI-A3H20/P storage carrier card blade is equipped with one 2.5" U.2 PCIe x4 slot and one M.2 2242/2280 PCIe x4 slot; the cPCI-A3H20/M storage carrier card blade is equipped with one M.2 2242/2280 PCIe x4 slot and 1x M.2 2242/2280 SATA slot.

The cPCI-A3H20 is designed for installation in standard CPCI-S.0 systems.

1.2 Features

- ▶ cPCI-A3H20/P
 - ▷ 1x 2.5" U.2 PCIe x4 slot
 - ▷ 1x M.2 2242/2280 PCIe x4 slot
- ▶ cPCI-A3H20/M
 - ▷ 1x M.2 2242/2280 PCIe x4 slot
 - ▷ 1x M.2 2242/2280 SATA slot

1.3 Contents

The cPCI-A3H20 is packaged with the following components. If any of the following items are missing or damaged, retain the shipping carton and packing material and contact the dealer for inspection. Please obtain authorization before returning any product to ADLINK. The packing contents of cPCI-A3H20 non-standard configurations will vary depending on customer requests.

- ▶ cPCI-A3H20 Storage Carrier Blade
- ▶ Screw pack for 2.5" U.2 drive (cPCI-A3H20/P only)
- ▶ Screw pack(s) for M.2 module (one pack for cPCI-A3H20/P, two packs for cPCI-A3H20/M)



NOTE:

The contents of non-standard cPCI-A3H20 configurations may vary depending on the customer's requirements.



CAUTION:

This product must be protected from static discharge and physical shock. Never remove any of the components except at a static-free workstation. Use the anti-static bag shipped with the product when putting the board on a surface. Wear an anti-static wrist strap properly grounded on one of the system's ESD ground jacks when installing or servicing system components.

2 Specifications

2.1 cPCI-A3H20 Storage Carrier Blade Specifications

CompactPCI® Standards	<ul style="list-style-type: none"> CompactPCI Serial PICMG CPCI-S.0 Specification
Mechanical	<ul style="list-style-type: none"> 3U 1-slot 4HP 160mm x 100mm (L x W) Equipped with P1 Conformal coating (by BOM option) Weight: 0.2 kg
System Interfaces	<ul style="list-style-type: none"> 1x PCIe x4 Gen 3 from P1
Onboard Slots	<p>cPCI-A3H20/P</p> <ul style="list-style-type: none"> 1x 2.5" U.2 PCIe x4 slot 1x M.2 M-Key 2242/2280 NVMe PCIe x4 slot <p>cPCI-A3H20/M</p> <ul style="list-style-type: none"> 1x M.2 M-Key 2242/2280 NVMe PCIe x4 slot 1x M.2 B-Key 2242/2280 SATA slot
Status LEDs	<ul style="list-style-type: none"> Power status LED 1: NVMe U.2 status (cPCI-A3H20/P only) LED 2: NVMe M.2 status LED 3: SATA M.2 status (cPCI-A3H20/M only)
Power Input	<ul style="list-style-type: none"> 12V: +9.5V min. to +15.5V max. 5Vsb: +5%/-3%
MTBF	<ul style="list-style-type: none"> 15.1 years minimum
Environmental	<ul style="list-style-type: none"> Operating Temperature: -40°C to 70°C (EN 50155:2021 OT4 Class, +85°C for 10 min.) when provided with 1.5m/s airflow Storage Temperature: -40°C to +85°C Operating Humidity: EN 50155:2021 10% to 95% relative humidity (non-condensing) Storage Humidity: 5% to 95% relative humidity (non-condensing) Altitude: 0 m to +2000 m Shock & Vibration: EN 50155:2021, EN 61373:2010 Category 1 Class B <p>Note: All above environmental specifications are dependent on storage devices installed on the carrier.</p>

Table 2-1: cPCI-A3H20 Storage Carrier Blade Specifications

Preliminary

Certifications	<ul style="list-style-type: none">• EN 50155:2021• EN 50121-3-2:2016• EN 55032:2015/A11:2020• CE, UKCA, FCC• Fire: Compliant to EN45545-2:2013+A1:2015 (HL 1-3) EL9 for PCB (R24 / R25)• Rolling Stock: BS EN 50155:2021• CE LVD: Meets this requirement when installed in a CE LVD compliant chassis
-----------------------	---

Table 2-1: cPCI-A3H20 Storage Carrier Blade Specifications

Preliminary

2.2 Block Diagrams

cPCI-A3H20 Storage Carrier Blade

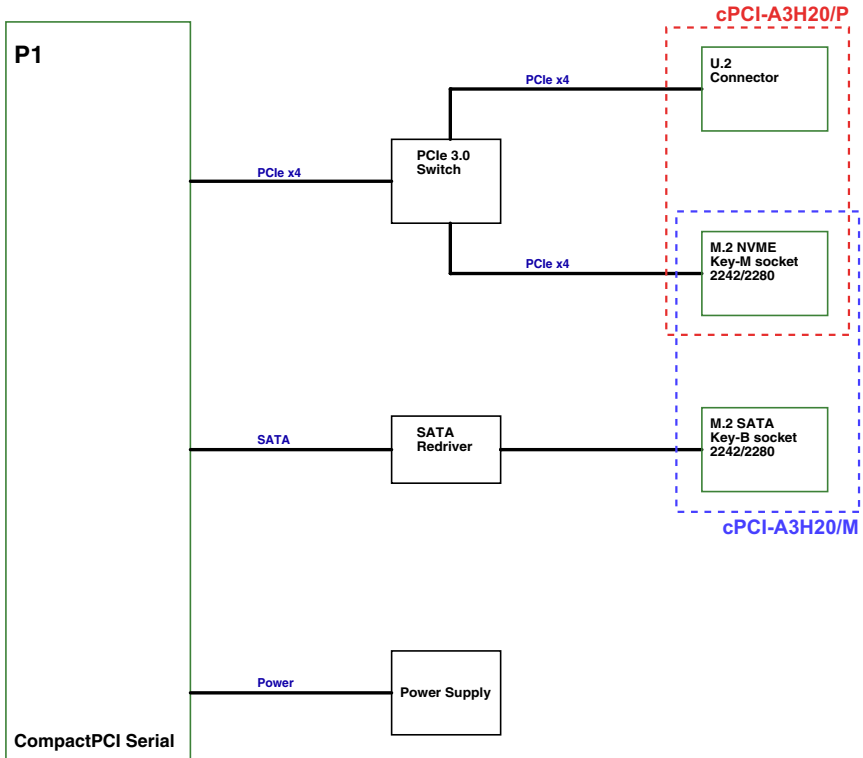

Figure 2-1: cPCI-A3H20 Functional Block Diagram

Preliminary

2.3 I/O Connectivity Table

Function	cPCI-A3H20/P		cPCI-A3H20/M	
	Faceplate	Onboard	Faceplate	Onboard
U.2 PCIe	-	Yes	-	-
M.2 PCIe	-	Yes	-	Yes
M.2 SATA	-	-	-	Yes
Status LEDs	Power U.2 NVMe M.2 NVMe	-	Power M.2 SATA M.2 NVMe	-

Table 2-2: cPCI-A3H20 I/O Connectivity

Preliminary

3 Board Interfaces

3.1 cPCI-A3H20 Board Layout

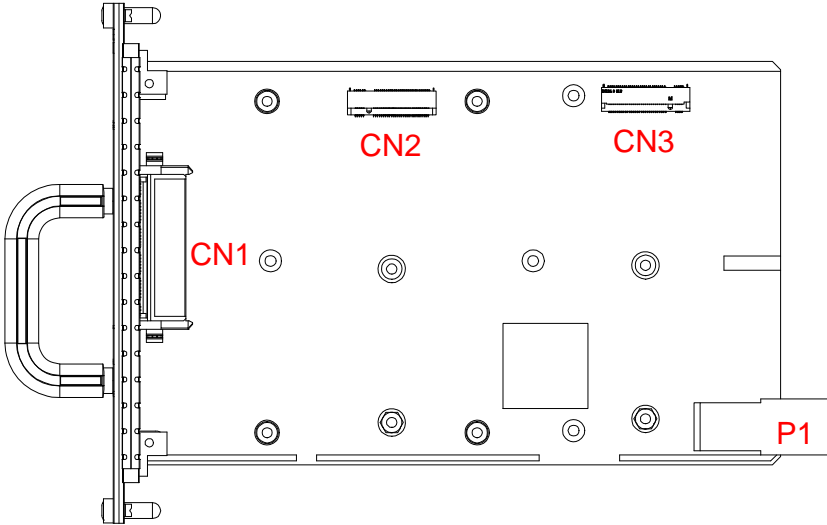

P1	CompactPCI Serial P1 connectors
CN1	U.2 NVMe connector
CN2	M.2 B-Key 2280 SATA connector
CN3	M.2 M-Key 2280 NVMe connector (PCIe mode only)

Figure 3-1: cPCI-A3H20 Board Layout

Preliminary

3.2 cPCI-A3H20/P Assembly Layout

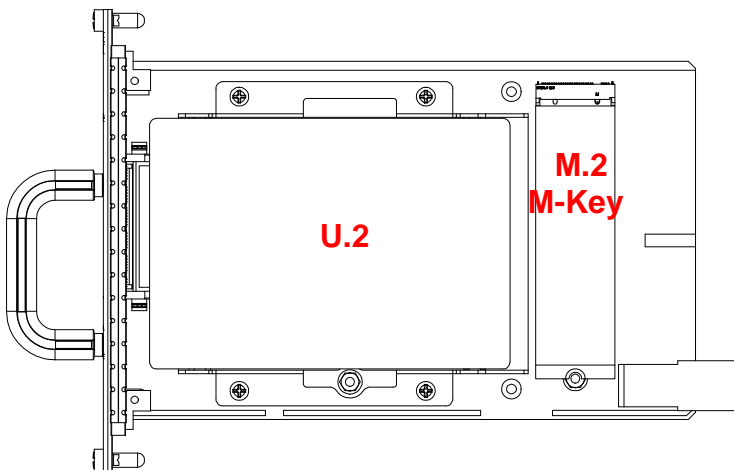

Figure 3-2: cPCI-A3H20/P Assembly Layout

3.3 cPCI-A3H20/M Assembly Layout

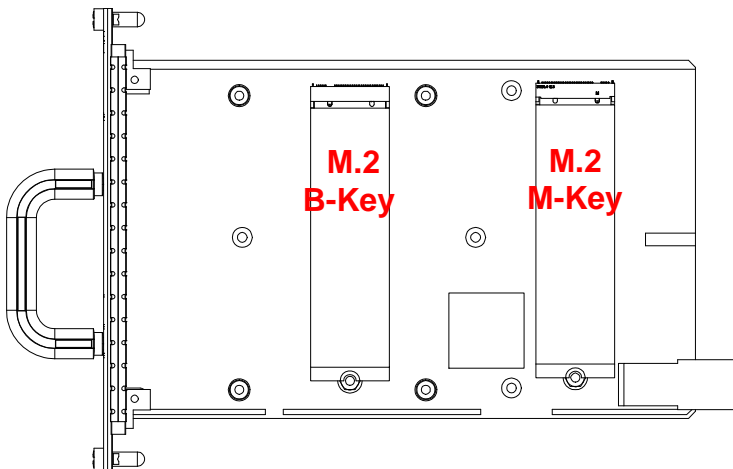

Figure 3-3: cPCI-A3H20/M Assembly Layout

Preliminary

3.4 cPCI-A3H20 Front Panel

Front Panel Layout

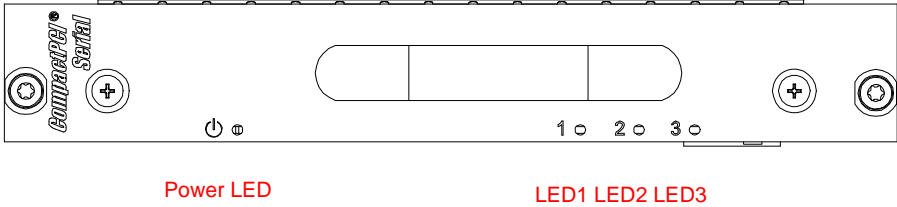

Figure 3-4: cPCI-A3H20 Front Panel Layout

Status LEDs

LED	Function	Condition	Indication
Power	Status	On	Power good
		Off	No power
1 (cPCI-A3H20/P only)	U.2 NVMe	On	Power good
		Blinking	Transmitting
		Off	Not working
2	M.2 NVMe	On	Power good
		Blinking	Transmitting
		Off	Not working
3 (cPCI-A3H20/M only)	M.2 SATA	On	Power good
		Blinking	Transmitting
		Off	Not working

Table 3-1: cPCI-A3H20 Front Panel Status LED Descriptions

Preliminary

3.5 Connector Pin Assignments

U.2 NVMe (CN1)

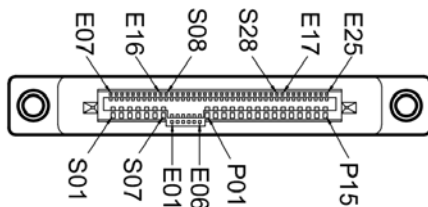

Pin	Signal Name	Pin	Signal Name
S1	GND	E7	U2_PCIE_CLK0_P
S2	N/C	E8	U2_PCIE_CLK0_N
S3	N/C	E9	GND
S4	GND	E10	U2_PCIE_TX0_P
S5	N/C	E11	U2_PCIE_TX0_N
S6	N/C	E12	GND
S7	GND	E13	U2_PCIE_RX0_N
E1	N/C	E14	U2_PCIE_RX0_P
E2	N/C	E15	GND
E3	P_+3V3_A	E16	N/C
E4	N/C	S8	GND
E5	PLTRST_U2_KEY_N	S9	N/C
E6	N/C	S10	N/C
P1	U2_WAKE_N	S11	GND
P2	sPCleRst	S12	N/C
P3	ClkReq#	S13	N/C
P4	FDET_N	S14	GND
P5	GND	S15	N/C
P6	GND	S16	GND
P7	N/C	S17	U2_PCIE_TX1_P
P8	N/C	S18	U2_PCIE_TX1_N
P9	N/C	S19	GND
P10	U2_PRSENT_N	S20	U2_PCIE_RX1_N

Table 3-2: U.2 NVMe Pin Definition

Preliminary

Pin	Signal Name	Pin	Signal Name
P11	LED_U2_ACT#	S21	U2_PCIE_RX1_P
P12	GND	S22	GND
P13	P_+12V_A	S23	U2_PCIE_TX2_P

Table 3-2: U.2 NVMe Pin Definition

Preliminary

M.2 Socket B-Key 2280 SATA (CN2)

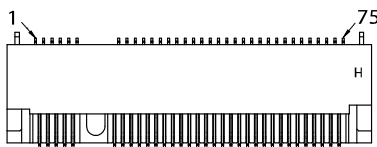

Pin	Signal Name	Pin	Signal Name
1	GND	2	P_+3V3_A
3	GND	4	P_+3V3_A
5	GND	6	TP10
7	P1_USB2_P	8	TP11
9	P1_USB2_N	10	LED_M2_KEYB_ACT#
11	GND		
B-Key			
21	GND	20	N/C
23	N/C	22	N/C
25	M2_1_DPR	24	N/C
27	GND	26	N/C
29	Reserved for USB	28	N/C
31	Reserved for USB	30	N/C
33	GND	32	N/C
35	Reserved for USB	34	N/C
37	Reserved for USB	36	N/C
39	GND	38	N/C
41	P1_SATA_M2_TX_P	40	N/C
43	P1_SATA_M2_TX_N	42	N/C
45	GND	44	N/C
47	P1_SATA_M2_RX_N	46	N/C
49	P1_SATA_M2_RX_P	48	N/C
51	GND	50	PLTRST_M2_KEY-B_N
53	N/C	52	M2_KEY-B_CLKREQ_N
55	N/C	54	M2_KEY-B_WAKE_N
57	GND	56	N/C
59	N/C	58	N/C

Table 3-3: M.2 B-Key 2280 SATA Pin Definition

Preliminary

Pin	Signal Name	Pin	Signal Name
61	N/C	60	N/C
63	N/C	62	N/C
65	N/C	64	N/C
67	PLTRST_M2_KEY-B_N	66	N/C
69	GND	68	N/C
71	GND	70	P_+3V3_A
73	GND	72	P_+3V3_A
75	GND	74	P_+3V3_A

Table 3-3: M.2 B-Key 2280 SATA Pin Definition



NOTE:

Pins 29, 31, 35 and 37 are reserved for USB. Please contact your ADLINK representative for more information.

Preliminary

M.2 Socket M-Key 2280 NVMe (CN3)

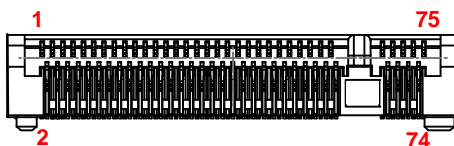

Pin	Signal Name	Pin	Signal Name
1	GND	2	P_+3V3_A
3	GND	4	P_+3V3_A
5	M2_PCIE_RX3_P	6	N/C
7	M2_PCIE_RX3_N	8	N/C
9	GND	10	LED_M2_KEYM_ACT#
11	M2_PCIE_TX3_P	12	P_+3V3_A
13	M2_PCIE_TX3_N	14	P_+3V3_A
15	GND	16	P_+3V3_A
17	M2_PCIE_RX2_P	18	P_+3V3_A
19	M2_PCIE_RX2_N	20	N/C
21	GND	22	N/C
23	M2_PCIE_TX2_P	24	N/C
25	M2_PCIE_TX2_N	26	N/C
27	GND	28	N/C
29	M2_PCIE_RX1_P	30	N/C
31	M2_PCIE_RX1_N	32	N/C
33	GND	34	N/C
35	M2_PCIE_TX1_P	36	N/C
37	M2_PCIE_TX1_N	38	M2_1_DEVSLP
39	GND	40	N/C
41	M2_PCIE_RX0_P	42	N/C
43	M2_PCIE_RX0_N	44	N/C
45	GND	46	N/C
47	M2_PCIE_TX0_P	48	N/C
49	M2_PCIE_TX0_N	50	PLTRST_M2_KEY-M_N
51	GND	52	M2_KEY-M_CLK_REQ_N

Table 3-4: M.2 M-Key 2280 NVMe Pin Definition

Preliminary

Pin	Signal Name	Pin	Signal Name
53	M2_PCIE_CLK0_N	54	M2_KEY-M_PEWAKE_N
55	M2_PCIE_CLK0_P	56	N/C
57	GND	58	N/C
M-Key			
67	NC	68	M2_1_SUSCLK
69	P_+3V3_A	70	P_+3V3_A
71	GND	72	P_+3V3_A
73	GND	74	P_+3V3_A
75	GND		

Table 3-4: M.2 M-Key 2280 NVMe Pin Definition

Preliminary

CompactPCI Serial P1 Connector

L	K	J	I	H	G	F	E	D	C	B	A	
1_PE_RX03-	1_PE_RX03+	GND	1_PE_TX03-	1_PE_TX03+	GND	1_PE_RX02-	1_PE_RX02+	GND	1_PE_TX02-	1_PE_TX02+	GND	6
GND	1_PE_RX01-	1_PE_RX01+	GND	1_PE_TX01-	1_PE_TX01+	GND	1_PE_RX00-	1_PE_RX00+	GND	1_PE_TX00-	1_PE_TX00+	5
1_SATA_Rx-	1_SATA_A_RX+	GND	1_SATA_TX-	1_SATA_TX+	GND	PE_CL_KIN-	PE_CL_KIN+	GND	1_USB_2-	1_USB_2+	GND	4
GA3	SATA_SL	SATA_SCL	GA2	SATA_SDO	SATA_SDI	GA1	1_USB_3_RX-	1_USB_3_RX+	GA0	1_USB_3_TX-	1_USB_3_TX+	3
SYSE_N#	PCIE_EN#	GND	WAKE_IN_OUT#	RST #	GND	Reser ved	Reser ved	GND	I2C_SDA	I2C_SCL	GND	2
GND	+12V	+12V	GND	+12V	+12V	GND	+12V	+12V	GND	P5VSB	+12V	1

Table 3-5: CompactPCI Serial P1 Connector Pin Definition

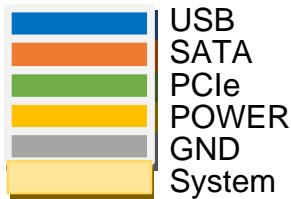

Figure 3-5: CompactPCI Serial P1 Pin Definition Legend

Preliminary

4 Getting Started

This chapter describes the following installation procedures for the cPCI-A3H20 carrier blade:

- ▶ 2.5" U.2 NVMe drive (cPCI-A3H20/P only)
- ▶ M.2 M-Key NVMe module
- ▶ M.2 B-Key SATA module (cPCI-A3H20/M only)

4.1 cPCI-A3H20/P

2.5" U.2 NVMe Drive Installation

The cPCI-A3H20/P provides space to install a 2.5" U.2 NVMe drive. Install the drive to the bracket by inserting it into the U.2 connector and fastening the four screws provided as shown below.

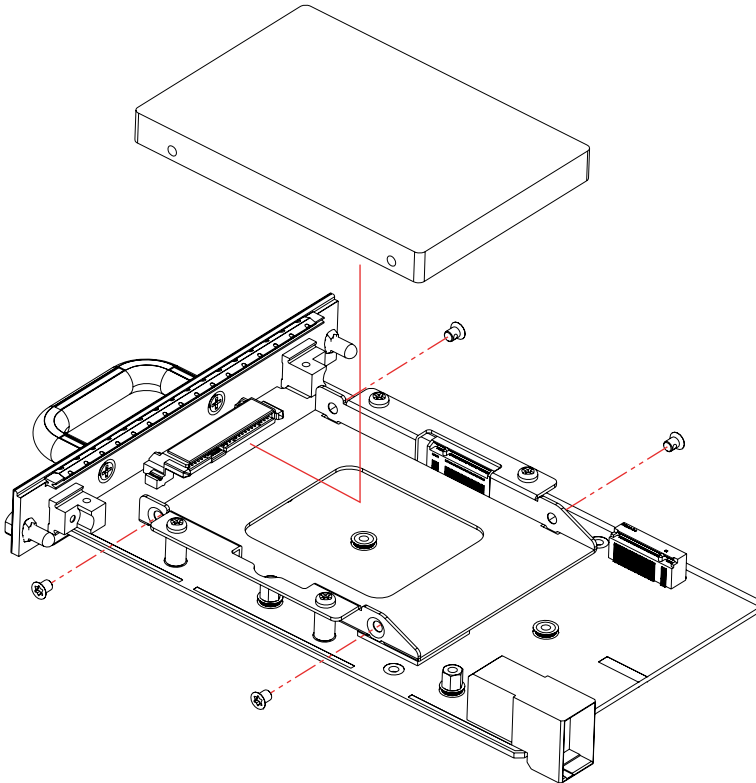

Preliminary

M.2 M-Key NVMe Module Installation

The cPCI-A3H20/P provides space to install an M.2 NVMe module. Install the module by inserting it into the M.2 connector and fastening the screw provided as shown below.

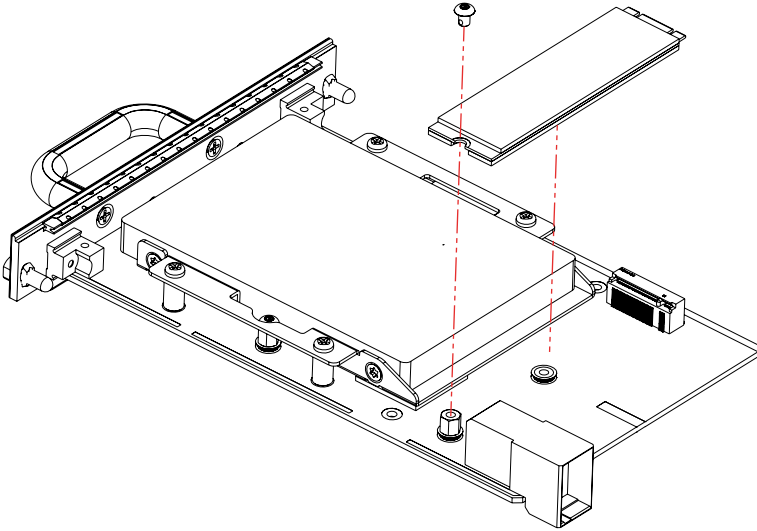

Preliminary

4.2 cPCI-A3H20/M

M.2 B-Key SATA and M-Key NVMe Module Installation

The cPCI-A3H20/M provides space to install an M.2 B-Key SATA and M.2 M-Key NVMe module. Install each module by inserting it into the corresponding M.2 connector and fastening the screw provided as shown below. Refer to “cPCI-A3H20 Board Layout” on page 7 for the locations of the M.2 B-Key SATA connector (CN2) and M.2 M-Key NVMe connector (CN3) locations.

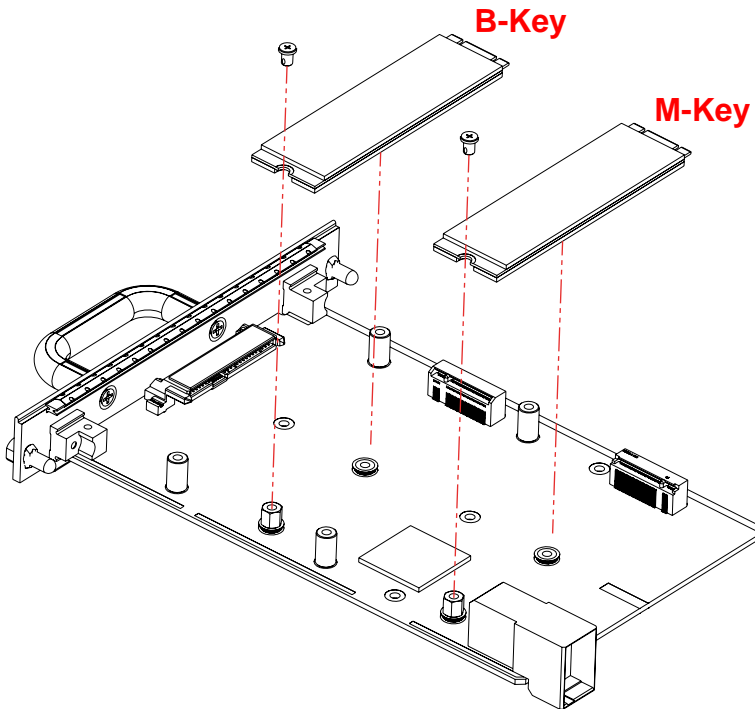

Preliminary

4.3 M.2 2242 Modules

To install M.2 2242 modules, remove the standoff from the default location (for M.2 2880 modules) and reinstall it in the location shown.

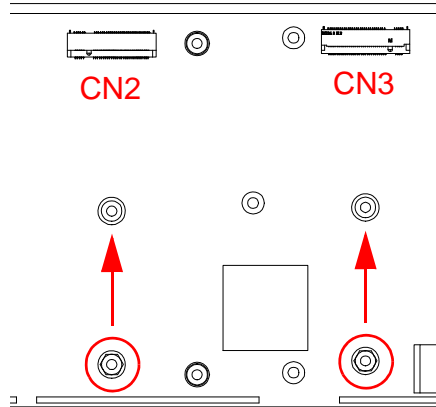

Preliminary

This page intentionally left blank.

Preliminary

Important Safety Instructions

For user safety, please read and follow all **instructions**, **WARNINGS**, **CAUTIONS**, and **NOTES** marked in this manual and on the associated equipment before handling/operating the equipment.

- ▶ Read these safety instructions carefully.
- ▶ Keep this user's manual for future reference.
- ▶ Read the specifications section of this manual for detailed information on the operating environment of this equipment.
- ▶ When installing/mounting or uninstalling/removing equipment:
 - ▷ Turn off power and unplug any power cords/cables.
- ▶ To avoid electrical shock and/or damage to equipment:
 - ▷ Keep equipment away from water or liquid sources;
 - ▷ Keep equipment away from high heat or high humidity;
 - ▷ Keep equipment properly ventilated (do not block or cover ventilation openings);
 - ▷ Make sure to use recommended voltage and power source settings;
 - ▷ Always install and operate equipment near an easily accessible electrical socket-outlet;
 - ▷ Secure the power cord (do not place any object on/over the power cord);
 - ▷ Only install/attach and operate equipment on stable surfaces and/or recommended mountings; and,
 - ▷ If the equipment will not be used for long periods of time, turn off and unplug the equipment from its power source.

- ▶ Never attempt to fix the equipment. Equipment should only be serviced by qualified personnel.

A Lithium-type battery may be provided for uninterrupted, backup or emergency power.



Risk of explosion if battery is replaced with one of an incorrect type. Dispose of used batteries appropriately.

- ▶ Equipment must be serviced by authorized technicians when:
 - ▷ The power cord or plug is damaged;
 - ▷ Liquid has penetrated the equipment;
 - ▷ It has been exposed to high humidity/moisture;
 - ▷ It is not functioning or does not function according to the user's manual;
 - ▷ It has been dropped and/or damaged; and/or,
 - ▷ It has an obvious sign of breakage.

Getting Service

Ask an Expert: <http://askanexpert.adlinktech.com>

ADLINK Technology, Inc.

No. 66, Huaya 1st Rd., Guishan District
Taoyuan City 333411, Taiwan
Tel: +886-3-216-5088
Fax: +886-3-328-5706
Email: service@adlinktech.com

Ampro ADLINK Technology, Inc.

6450 Via Del Oro
San Jose, CA 95119-1208, USA
Tel: +1-408-360-0200
Toll Free: +1-800-966-5200 (USA only)
Fax: +1-408-600-1189
Email: info@adlinktech.com

ADLINK Technology (China) Co., Ltd.

300 Fang Chun Rd., Zhangjiang Hi-Tech Park
Pudong New Area, Shanghai, 201203 China
Tel: +86-21-5132-8988
Fax: +86-21-5132-3588
Email: market@adlinktech.com

ADLINK Technology GmbH

Hans-Thoma-Strasse 11
D-68163 Mannheim, Germany
Tel: +49-621-43214-0
Fax: +49-621 43214-30
Email: emea@adlinktech.com

Please visit the Contact page at **www.adlinktech.com** for information on how to contact the ADLINK regional office nearest you.

Preliminary