

NuPRO-780 Series
PICMG Full-size CPU Card
User's Guide



Recycled Paper

©Copyright 2001 ADLINK Technology Inc.

Manual Rev. 1.00 : November 22, 2001

Part NO: 50-13024-100

The information in this document is subject to change without prior notice in order to improve reliability, design and function and does not represent a commitment on the part of the manufacturer.

In no event will the manufacturer be liable for direct, indirect, special, incidental, or consequential damages arising out of the use or inability to use the product or documentation, even if advised of the possibility of such damages.

This document contains proprietary information protected by copyright. All rights are reserved. No part of this manual may be reproduced by any mechanical, electronic, or other means in any form without prior written permission of the manufacturer.

Trademarks

NuPRO is a registered trademark of ADLINK Technology Inc.,

Other product names mentioned herein are used for identification purposes only and may be trademarks and/or registered trademarks of their respective companies.

Getting service from ADLINK

- Customer Satisfaction is always the most important thing for ADLINK Tech Inc. If you need any help or service, please contact us and get it.

ADLINK Technology Inc.			
Web Site	http://www.adlink.com.tw		
	http://www.adlinktechnology.com		
Sales & Service	service@adlink.com.tw		
Technical Support	NuDAQ + USBDAQ		nudaq@adlink.com.tw
	NuDAM		nudam@adlink.com.tw
	NuIPC		nuipc@adlink.com.tw
	NuPRO		nupro@adlink.com.tw
	Software		sw@adlink.com.tw
TEL	+886-2-82265877	FAX	+886-2-82265717
Address	9F, No. 166, Jian Yi Road, Chungho City, Taipei, 235 Taiwan, R.O.C.		

- Please inform or FAX us of your detailed information for a prompt, satisfactory and constant service.

Detailed Company Information			
Company/Organization			
Contact Person			
E-mail Address			
Address			
Country			
TEL		FAX	
Web Site			
Questions			
Product Model			
Environment to Use	OS:		
	Computer Brand:		
	M/B:	CPU:	
	Chipset:	BIOS:	
	Video Card:		
	Network Interface Card:		
Other:			
Challenge Description			
Suggestions to ADLINK			

Table of Contents

Chapter 1 Introduction	1
1.1 Checklist.....	2
1.2 Description	2
1.3 Features	2
1.4 Specifications.....	4
1.5 Intelligence	7
1.6 PCB Layout Drawing	7
1.7 Mechanical Drawing	8
Chapter 2 Installation	9
2.1 CPU Installation	9
2.2 Memory Installation	10
2.3 Jumpers on the NuPRO-780	10
Chapter 3 Watchdog Programming	22
Chapter 4 Intel 815 Chipset Hardware and VGA Driver.....	26
4.1 Hardware Configuration File Installation.....	26
4.2 VGA Driver Installation	28
Chapter 5 LAN Driver Installation	30
5.1 Software and Drivers Support	30
5.2 Driver Installation on Windows 2000.....	31
5.3 Driver Installation on Windows 98.....	32
5.4 Driver Installation on Windows NT.....	33
Product Warranty/Service	34

How to Use This Guide

This manual is designed to help you to use the NuPRO-780 series.

- Chapter 1, “Introduction”** gives an overview of the product features and specifications.
- Chapter 2, “Installation”** describes how to install the SBC. The PCB layout, jumper setting and connector pin assignments are shown.
- Chapter 4 “Watchdog Programming** shows the functionality of the watchdog timer.
- Chapter 5, “Intel 815 Chipset Hardware and VGA Driver”** describes how to install the VGA and Hardware drivers of the i815 chipset.
- Chapter 6, “LAN driver installation”** describes how to install the LAN driver for NuPRO-780 SBC.

NuPRO-780 Series Function List

Model	NuPRO-780DV	NuPRO-780LV
Processor	Pentium III / Celeron / C3	Pentium III / Celeron / C3
Chipset	Intel i815E B-Stepping	Intel i815E B-Stepping
BIOS	Award	Award
Max. SDRAM	512MB un-buffered	512MB un-buffered
Memory Sockets	2 x DIMM	2 x DIMM
VGA	Integrated in i815	Integrated in i815
Ethernet (10/100Mbps)	Dual LAN (i815 + 82559)	Single LAN (i815)
mPCI	Yes	Yes
Multi I/O Chip	Winbond 83627HF	Winbond 83627HF
Enhanced IDE (ATA-100)	Yes	Yes
2S/1P	Yes	Yes
USB	Yes	Yes
IrDA	Yes	Yes
Audio	Optional Module	Optional Module
H/W Monitoring	Winbond 83627HF	



Introduction

This manual is designed to give you information on the NuPRO-780 series CPU card. The information inside this user's manual can be applied to NuPRO-780 series if without specified.

The topics covered in this chapter are as follows:

- Checklist
- Description
- Features
- Specifications
- Intelligence
- PCB Layout Drawing
- Mechanical Drawing

1.1 Checklist

Please check that your package is complete and contains the items below. If you discover damaged or missing items, please contact your dealer.

- The NuPRO-780 Industrial Computer Main Board
- This User's Manual
- 1 IDE Ribbon Cable (ATA-100)
- 1 Floppy Ribbon Connector
- 1 Serial Port Ribbon Cable and 1 Parallel Port Cable
- 1 PS/2 Y cable for mouse and keyboard
- 1 CD Containing hardware configuration file, VGA Driver, LAN Driver and Hardware Monitor utility

1.2 Description

The NuPRO-780 is a Intel i815E based Industrial Computer main board with the ICH2 (i82801) chipset and is fully designed for harsh industrial environment. It built-in the VGA / LAN. This board accommodates up to 512MB SDRAM configuration.

The NuPRO-780 comes with Winbond's 83627HF Super I/O chip. The hardware monitoring device (Winbond W83782D) monitors system and CPU temperature, system voltages.

1.3 Features

- Supports Socket-370 based Intel Pentium III / Celeron (FC-PGA & FC-PGA2) & VIA C3 CPU up to 133MHz FSB
- Intel i82815E chipset (built-in VGA controller)
- Up to 512MB SDRAM system memory (2 x 168-pin DIMM sockets)
- IDE support up to Ultra/DMA100
- One RS-232 and one RS-232/422/485 (With RS-485+ Auto-Direction Control) interface
- High speed bi-directional SPP/ECP/EPP parallel port
- Programmable watchdog timer
- Hardware Monitoring
- Single (NuPRO-780LV) or Dual (NuPRO-780DV) 10/100 Base-T Ethernet interface

- AC'97 Link interface support DB-AC97S board for audio input & output
- One 32-bit/33MHz mPCI Bus which compatible with most of standard MiniPCI Type III or ADLINK's mPCI add-on cards
- ISA High Drive 64mA
- Standard ATX power connector on board
- External LAN status LED connectors
- The mounting holes around it to fit the board into chassis without Backplane (When using standard ATX power connector as power source)

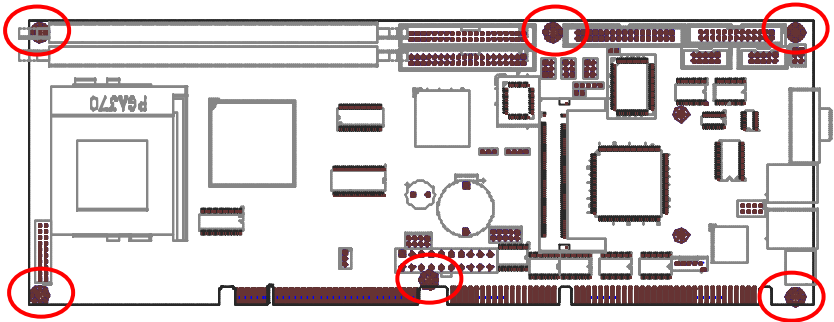

1.4 Specifications

- ◆ **Processor Socket:** Socket-370 connector
- ◆ **Processor:** Intel Celeron and Pentium III (FC-PGA & FC-PGA2), VIA C3 CPU
- ◆ **Secondary Cache: built in CPU**
- ◆ **Bus Speed:** 66/100/133MHz
- ◆ **Chipset: Intel i82815E**
- ◆ **Memory Sockets:**
 - Two 168-pin DIMM sockets
 - Max. 512MB SDRAM
 - Memory type: PC-133 un-buffered SDRAM
- ◆ **Integrated Graphics Controller:**
 - 3D Graphics Visual Enhancement
 - 24-bit 230 MHz RAMDAC
 - DDC2B compliant
 - Up to 1600x1200 in 8-bit color at 85Hz refresh rate
- ◆ **BIOS: Award BIOS, support PnP**
 - Intel 82802AB Firmware Hub (512KB) for BIOS update
 - DMI BIOS Support: Desktop Management Interface (DMI) allows users to download system hardware-level information such as CPU type, CPU speed, internal/external frequencies and memory size.
 - Green Function: Power management via BIOS, activated through mouse/keyboard movement
- ◆ **PCI Compliance:** Fully compliant to PCI rev. 2.1 standards
- ◆ **CRT:**
 - On-board VGA Controller Built-in AGP (3D hyper pipelined architecture)
 - Video memory sharing from main memory with Intel Dynamic Video Memory Technology (DVMT)
 - 4MB Display Cache On Board

- Memory size is controlled by device driver from 1 MB up to 11 MB
- ◆ **PCI Bus Ethernet Interface:**
 - Primary port : Built-in i815E chip + 82562EM (All of NuPRO-780 series)
 - Secondary port : Intel 82559 (For NuPRO-780DV only)
 - PCI local bus Ethernet controller
 - 10/100Mbps operation in a single port PCI bus master architecture
 - IEEE 802.3 10base-T and 100base-TX compatible physical longer support
 - IEEE802.3u auto-negotiation support for automatic speed selection
 - IEEE 802.3X (100base-TX Flow control support)
 - Wake on LAN support
 - External LAN status LED connectors
- ◆ **Enhanced IDE:** Bus Master IDE controller, two EIDE interfaces for up to four devices, support PIO Mode 3/4 or Ultra DMA/100 IDE devices, including Hard Disk Drive, ATAPI CD-ROM, LS120, and ZIP drives.
- ◆ **Super I/O Chipset: Winbond W83627HF**
- ◆ **Parallel Port:**
 - One high-speed parallel port, SPP/EPP/ECP mode
 - ESD protection to 4KV
 - Downstream device protection to 30V
- ◆ **Serial Port:**
 - One 16550 UART compatible ports with RS-232 interface
 - One 16550 UART compatible ports with RS-232/422/485 (With RS-485+ Auto-Direction Technology)
 - ESD protection to 2KV
- ◆ **FDD Interface:** Two floppy drives (360KB, 720KB, 1.2MB, 1.44MB, 2.88MB)
- ◆ **USB Interface:** Two USB pin-header connectors, compliant with USB Specification Rev. 1.1, Individual over-current protection
- ◆ **AC'97 Link:**

- One 10 pin connector for DB-AC97S board
- ◆ **Watchdog Timer:**
 - Programmable I/O port 2Eh and 2Fh to configure watchdog timer
 - Time-out timing select 0~255 seconds or 0~255 minutes
- ◆ **Keyboard and Mouse Connectors:**
 - One PS/2 type mini-DIN connectors for PS/2 Keyboard & Mouse (When using Combo Cable)
 - Supports a 6-pin internal keyboard/mouse connector
- ◆ **HISA:** ISA bus high driving capability up to 64mA on all address and control lines
- ◆ **Power supply:** AT/ATX
- ◆ **Environmental:**
 - Storage Temperature: -20°C to 80°C
 - Operation Temperature: 0°C to 55°C
 - Humidity: 5% to 95%
- ◆ **Power Requirement:**

Power Type	Value (MAX)	Unit	Note
+5V	7800	mA	
+12V	150	mA	1
-12V	100	mA	
+5VSB	50	mA	

1. Without FAN current.

System configuration : NuPRO-780DV, Intel Pentium III/1GB (133MHz FSB), 256MB SDRAM x 2

Note: The above values are the maximum power requirement for SBC with CPU and RAM only, the CPU is running under fully loading. The power for all the other peripheral devices such as keyboard, mouse, add-on cards, HDD, or CD ROM is not included.

- ◆ **Dimension:** 338mm x 122mm(13.3" x 4.8")

1.5 Intelligence

- ◆ **System Health Monitoring:**

A sensor for the CPU temperature on the NuPRO-780 monitors the CPU temperature, an external sensor for system temperature, case-opened indicator, fan-speed detection, system voltages monitoring.

- ◆ **Windows 98 shut-off:**

Allows shut-off control from within Windows 98 and through an ATX power supply.

- ◆ **Wake On LAN:**

Through an ATX power supply and network connection, systems can be turned on from the power-off state.

1.6 PCB Layout Drawing

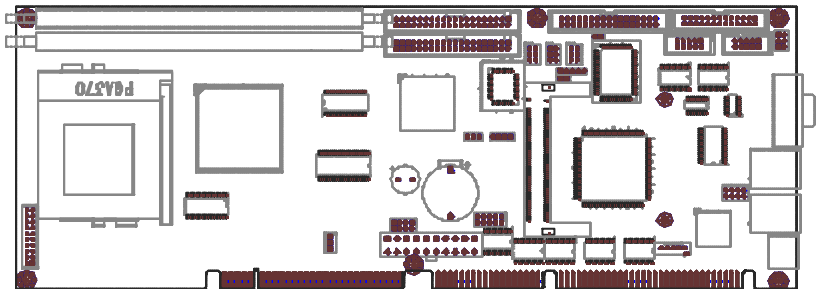

1.7 Mechanical Drawing

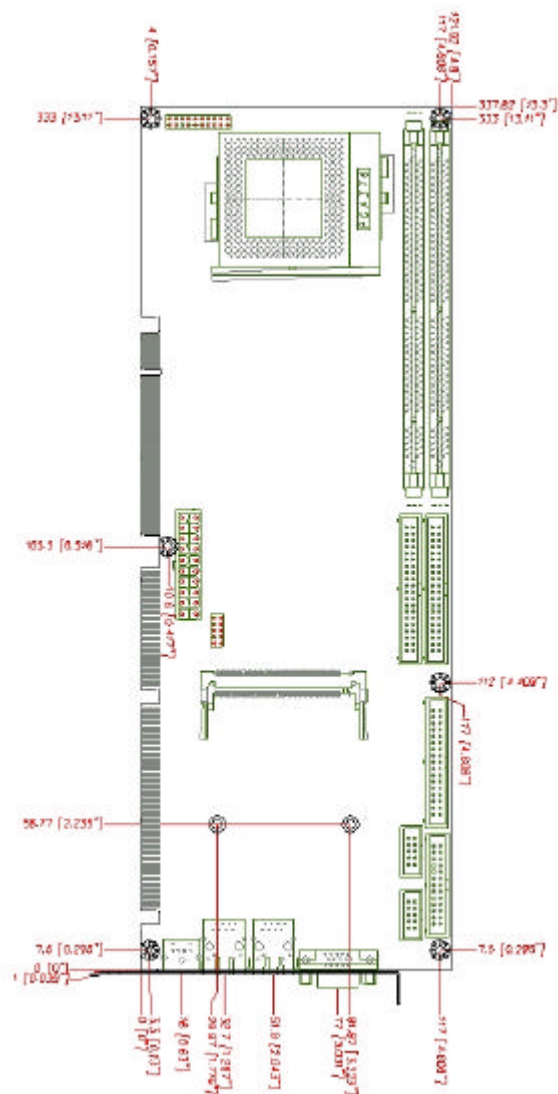

2

Installation

This chapter provides information on how to use the jumpers and connectors on the NuPRO-780 in order to set up a workable system. The topics covered are:

- Memory Installation
- Jumpers Setting
- Connectors Pin Assignments

2.1 CPU Installation

The NuPRO-780 industrial computer Main board supports a Socket-370 processor socket for Intel Celeron, Pentium III FC-PGA/FC-PGA2 and VIA C3 processors.

Before inserting the CPU, make sure the notch on the corner of the CPU corresponds with the notch on the inside of the socket.

Note: Ensure that the CPU cooler does fully contact with the CPU top surface to avoid CPU overheating that would cause your system to hang or be unstable.

2.2 Memory Installation

The NuPRO-780 industrial computer main board supports two 168-pin DIMM sockets for a maximum total memory of 512MB. The memory modules can come in sizes of 32MB, 64MB, 128MB, and 256MB SDRAM.

2.3 Jumpers on the NuPRO-780

The jumpers on the NuPRO-780 allow you to configure your main board according to the needs of your applications. If you have doubts about the best jumper configuration for your needs, contact your dealer or sales representative. The figure and table below show the correct setting to match the CPU frequency.

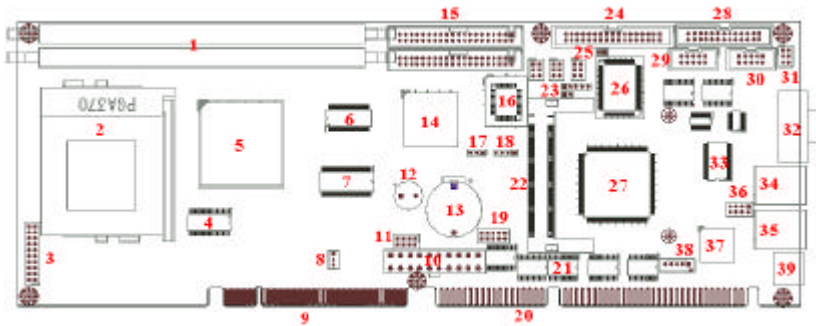

Position	Description	Reference
3	Front Panel Pin Header	CN21
8	Fan Connector	FN1
10	ATX Power Connector	CN18
11	USB1.1 Pin Header	CN19
15	IDE1 and IDE2	CN15, CN14
17	Clear CMOS Jumper	JP6
18	SMBus Pin Header	CN16
19	AC'97 Pin Header	CN17
22	MiniPCI Type III Socket	CN13
23	COM2 Port Function Selector Jumper IrDA Pin Header Case Open Pin Header	JP2, JP3, JP4; CN12; JP5
24	Floppy Disk Connector	CN10
25	External Temperature Pin Header	CN11

28	PRINTER Port	CN7
29	COM1 Port	CN8
30	COM2 Port	CN1
31	RS-485 / RS-485+ Directed Function Selector Jumper	JP1
32	VGA Connector	CN2
34	LAN1 Connector (RJ-45)	CN3
35	LAN2 Connector (RJ-45)	CN6
36	LAN LED Pin Header	CN4
38	Internal KBD Connector	CN9
39	KB/MS Connector	CN5

COM2 Function Selection – JP4, JP3 and JP2

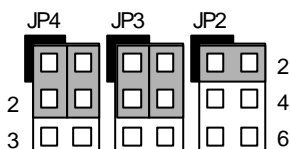

JP4 JP3	JP2	FUNCTION
1-2 4-5	1-2	RS-232
1-2 4-5	3-4	RS-422
2-3 5-6	5-6	RS-485

Clean CMOS Jumper – JP6

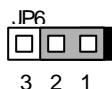

JP6	FUNCTION
1-2	Normal
2-3	Clean CMOS

COM2 RS-485 Function Selection – JP1

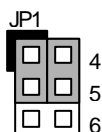

JP1	FUNCTION
1-2 4-5	RS-422 / RS-485
2-3 5-6	RS-485+

RS-485+ is a auto-direction flow control function which control the flow automatically. If system is running under Windows and connection by RS-485 half-duplex transmutations, we suggestion set to RS-485+ mode.

VGA Connector – CN2

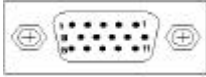

PIN	SIGNAL	PIN	SIGNAL
1	RED	9	V_PWR
2	GREEN	10	GND
3	BLUE	11	+5V
4	+5V	12	I ² C_DATA
5	GND	13	V_HSYNC
6	GND	14	V_VSYNC
7	GND	15	I ² C_CLK
8	GND		

Keyboard/Mouse Connector – CN5

Please using ADLINK's Y-Cable when using Keyboard and Mouse at same time. The cable is following the PC'99 standard, purple for Keyboard and Green for Mouse. And it also for Keyboard only if connected without Y-Cable.

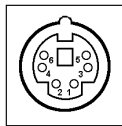

PIN	SIGNAL
1	KBDAT
2	MSDAT
3	KYMSE_GND
4	KB5V
5	KBCLK
6	MSCLK

LAN RJ45 Connector – CN3 and CN6

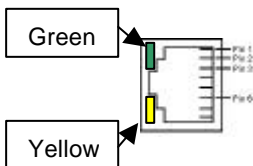

PIN	SIGNAL	PIN	SIGNAL
1	LAN1_TDP	1	LAN2_TDP
2	LAN1_TDN	2	LAN2_TDN
3	LAN1_RDP	3	LAN2_RDP
4	NC	4	NC
5	NC	5	NC
6	LAN1_RDN	6	LAN2_RDN
7	NC	7	NC
8	GND	8	GND

LAN LED status

LED Color	Status	Function
Green (Speed status)	ON	100Mbps
	OFF	10Mbps
Yellow (Link status)	ON	Link
	OFF	Link off
	Blinking	Data transfer in progress

Dual USB Connector – CN19

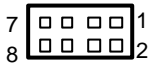

PIN #	PIN #	Signal Name
1	2	VCC
3	4	USB0- / USB1-
5	6	USB0+ / USB1+
7	8	Ground

General Purpose System Signals – CN21

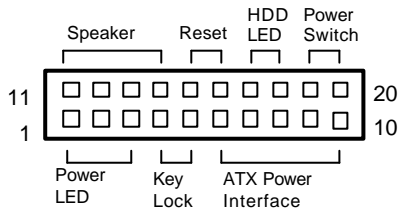

PIN	SIGNAL	FUNCTION	PIN GROUP
1	+5V	Power	Power LED
2	NC		
3	PLED	Power LED signal	
4	KEYLOCK	Keyboard lock	Key Lock
5	GND	Ground	
6	GND	Ground	ATX Power Connector
7	NC		
8	PWRON	Power-on signal	
9	+5VSB	Standby Power	

10	PME#	Power Management Event	
11	WDSPK	Speaker signal	Chassis Speaker
12	NC		
13	NC		
14	+5V	Power	
15	RESETBT	RESET Button signal	RESET button
16	GND	Ground	
17	HDDLED	Hard Disk LED signal	Hard Disk LED
18	+5V	Power	
19	PWRBT	POWER Button signal	Power on button
20	GND	Ground	

- **Power LED and Keylock: Pins 1 - 5**

The power LED indicates the status of the main power switch. The Keylock# signal is used to disable the keyboard function when it is short to GND.

- **ATX Power Interface: Pins 6 -10**

The +5V standby power input from pin #9 and #10. The Poweron# signal is connected to the ATX power supply to control the power On/Off.

- **Speaker: Pins 11 - 14**

This connector provides an interface to a speaker for audio tone generation. An 8-ohm speaker is recommended.

- **Reset Switch: Pins 15 and 16**

The reset switch allows the user to reset the system without turning the main power switch off and then on again. Orientation is not required when making a connection to this header.

- **Hard Disk LED Connector: Pins 17 and 18**

This connector connects to the hard drive activity LED on control panel. This LED will flash when the HDD is being accessed.

- **ATX Power ON Switch: Pins19 and 20**

This 2 -pin connector is an “ATX Power Supply On/Off Switch” on the system that connects to the power switch on the case. When pressed, the power switch will force the system to power on. When pressed it for 4 seconds, it will force the system to power off.

Ethernet LED Connector – CN4

The connector is designed for extra LAN status LED which can display the LAN status by another LED, custom can design these LED on front panel.

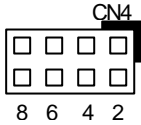

PIN	SIGNAL	FUNCTION
1	LED1_A	LAN Active
3	LED1_L	LAN Link
5	LED1_S	LAN Speed
7	GND	Ground
2	LED2_A	LAN Active
4	LED2_L	LAN Link
6	LED2_S	LAN Speed
8	GND	Ground

External Thermal Connector – CN11

The connector is connected to the thermal sensor which can detect the system temperature for application program's monitoring.



PIN	SIGNAL	FUNCTION
1	TGND	Thermal Ground
2	VTIN	Thermal Voltage Input

Case Open Connector – JP5

The signal is connected to the limit switch sensor of the chassis to detect the case open or closed.



Shorted	Open
Case Closed	Case Open

COM1 Serial Port Connector – CN8

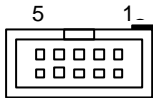

PIN #	RS-232
1	DCD, Data carrier detect
2	RXD, Receive data
3	TXD, Transmit data
4	DTR, Data terminal ready
5	GND, ground
6	DSR, Data set ready
7	RTS, Request to send
8	CTS, Clear to send
9	RI, Ring indicator
10	NC

COM2 Serial Port Connector – CN1

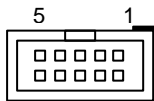

PIN #	RS-232	RS-422	RS-485
1	DCD, Data carrier detect	TX-	DATA-
2	RXD, Receive data	TX+	DATA+
3	TXD, Transmit data	RX+	NC
4	DTR, Data terminal ready	RX-	NC
5	GND, ground	GND	GND
6	DSR, Data set ready	NC	NC
7	RTS, Request to send	NC	NC
8	CTS, Clear to send	NC	NC
9	RI, Ring indicator	NC	NC
10	NC	NC	NC

DB-9 connector for COM1 / COM2 (RS-422/485 for COM2 only)

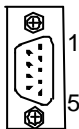

PIN #	RS-232	RS-422	RS-485
1	DCD, Data carrier detect	TX-	DATA-
2	RXD, Receive data	TX+	DATA+
3	TXD, Transmit data	RX+	NC
4	DTR, Data terminal ready	RX-	NC
5	GND, ground	GND	GND
6	DSR, Data set ready	NC	NC
7	RTS, Request to send	NC	NC
8	CTS, Clear to send	NC	NC
9	RI, Ring indicator	NC	NC

Floppy Drive Connector – CN10

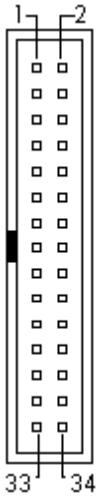

Signal Name	PIN #	PIN	Signal Name
Ground	1	2	Drive density selection
Ground	3	4	No connect
Ground	5	6	Drive density selection
Ground	7	8	Index
Ground	9	10	Motor enable 0
Ground	11	12	Drive select 1
Ground	13	14	Drive select 0
Ground	15	16	Motor enable 1
Ground	17	18	Direction
Ground	19	20	Step
Ground	21	22	Write data
Ground	23	24	Write gate
Ground	25	26	Track 00
Ground	27	28	Write protect
Ground	29	30	Read data
Ground	31	32	Side 1 select
Ground	33	34	Diskette change

Parallel Port Connector – CN7

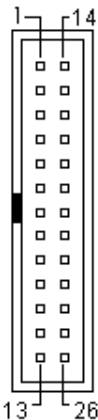

Signal Name	PIN #	PIN #	Signal Name
Line printer strobe	1	14	AutoFeed
PD0, parallel data 0	2	15	Error
PD1, parallel data 1	3	16	Initialize
PD2, parallel data 2	4	17	Select
PD3, parallel data 3	5	18	Ground
PD4, parallel data 4	6	19	Ground
PD5, parallel data 5	7	20	Ground
PD6, parallel data 6	8	21	Ground
PD7, parallel data 7	9	22	Ground
ACK, acknowledge	10	23	Ground
Busy	11	24	Ground
Paper empty	12	25	Ground
Select	13	N/A	N/A

Primary & Secondary IDE Interface Connectors – CN15 & CN14

PIN	DESCRIPTION	PIN	DESCRIPTION
1	RESET#	2	GROUND
3	DATA7	4	DATA8
5	DATA6	6	DATA9
7	DATA5	8	DATA10
9	DATA4	10	DATA11
11	DATA3	12	DATA12
13	DATA2	14	DATA13
15	DATA1	16	DATA14
17	DATA0	18	DATA15
19	GROUND	20	NC
21	NC	22	GROUND
23	IOW#	24	GROUND
25	IOR#	26	GROUND
27	IOCHRDY	28	GROUND
29	NC	30	GROUND
31	INTERRUPT	32	IOCS16#
33	SA1	34	NC
35	SA0	36	SA2
37	HDC CS0#	38	HDC CS1#
39	HDD ACTIVE#	40	GROUND
41	VCC	42	VCC
43	GROUND	44	NC

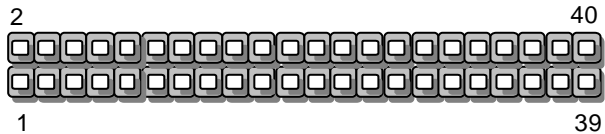

ATX Power Connector – CN18

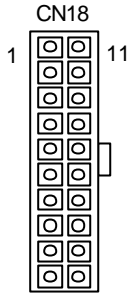

PIN	SIGNAL	PIN	SIGNAL
1	+3.3V	11	+3.3V
2	+3.3V	12	-12V
3	GND	13	GND
4	+5V	14	PS_ON_L
5	GND	15	GND
6	+5V	16	GND
7	GND	17	GND
8	POWER GOOD	18	-5V
9	STB5V	19	+5V
10	+12V	20	+5V

CPU FAN Connector – FN1



PIN	Signal
1	GND
2	FAN_12V
3	FANSPD_1

IrDA Connector – CN12

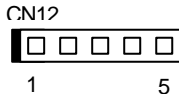

PIN	SIGNAL
1	+5V
2	NC
3	IRRXD
4	GND
5	IRTXD

Internal KBD Connector – CN9



PIN #	Signal Name
1	Vcc (+5V)
2	GND
3	NC
4	KBD Data
5	KBD Clock

MiniPCI Connector – CN13

This connector is following the MiniPCI Type III standard which is designed for the most of laptop computer. This connector is design for most of application such as SCSI, LCD, LAN or others. Please contact with ADLINK's reseller for more detail information.

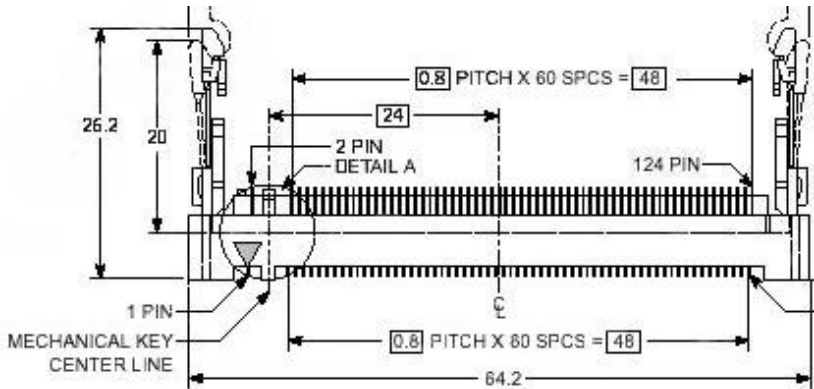

SMBus Connector – CN16

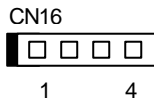

PIN	SIGNAL	FUNCTION
1	+5V	Power
2	SMBCLK	Clock
3	SMBDATA	Data
4	GND	Ground

AC'97 (AC'97 Link) Connector – CN21

This connector is an optional function which can be connected to the DB-AC97s board for AC'97 audio in/out. DB-AC97S support Line-in, Line-Out, CDROM-in connector. Please contact with ADLINK's reseller for this board.

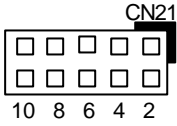

PIN	SIGNAL	FUNCTION
1	GND	Ground
3	GND	Ground
5	+5V	Power
7	+5V	Power
9	AC_SYNC	Synchro-signal
2	AC_BITCLK	Bit Clock
4	AC_SDIN0	Data Input 0
6	AC_SDOOUT	Data Output
8	AC_SDIN1	Data Input 1
10	AC_RSTJ	Reset

3

Watchdog Programming

NuPRO-780 implements a watchdog timer embedded in the 83627HF. It contains a one-second/minute resolution down counter (in CRF6 of logical device 8 of 83627HF) and two Watchdog control registers (CRF5 and CRF7 of logical device 8). Once setup a value to WDT, the timer begins to count down.

Any movement of keyboard, mouse or software re-setup the value will reload the timer value. The Watchdog output is connected to “reset”. When the system hangs up without software re-trigger, the system will be reset.

So basically this is a watchdog timer that has a 1 second granularity up to 255 seconds or a 1 minute granularity up to 255 minutes. The keyboard and mouse will only reset WDT if Bit 7 and 6 of CRF7 is set, that is values greater than C0h or 192 decimal.

To configure the registers, the following sequence should be followed :

1. Writing 87h to location 2Eh twice to enter into the extended function mode.
2. Configure the registers to set up WDT.
3. Writing 0AAh to location 2Eh to exit the extended function mode.

The example shown below will reset the system after 15 seconds. Both keyboard and mouse interrupts will reload WDT from CRF6.

```

begin:
;-----;
Enter the extend function mode, interrupt double-write
;-----;
    mov     dx,2eh
    mov     al,87h
    out     dx,al
    out     dx,al

    mov     dx,2eh
    mov     al,2bh           ;CR2B, bit4-> 0 = WDTO
                             ;          bit4-> 1 = GP24
    out     dx,al
    mov     dx,2fh
    mov     al,0c0h
    out     dx,al

    mov     dx,2eh
    mov     al,07h
    out     dx,al
    mov     dx,2fh
    mov     al,08h           ;device 8
    out     dx,al

    mov     dx,2eh
    mov     al,30h
    out     dx,al
    mov     dx,2fh
    mov     al,01h           ;enable device 8
    out     dx,al

    mov     dx,2eh
    mov     al,07h
    out     dx,al
    mov     dx,2fh
    mov     al,08h           ;device 8
    out     dx,al

    mov     dx,2eh
    mov     al,0f7h
    out     dx,al           ;device 8,CRF7

```

```

mov     dx,2fh
mov     al,0c0h
out     dx,al

mov     dx,2eh
mov     al,07h
out     dx,al
mov     dx,2fh
mov     al,08h
out     dx,al           ;device 8

mov     dx,2eh
mov     al,0f5h         ;device 8, CRF5
out     dx,al
mov     dx,2fh
mov     al,00h         ;bit3 -> 0 = second
                        ;bit3 -> 1 = minute
out     dx,al

mov     dx,2eh
mov     al,07h
out     dx,al
mov     dx,2fh
mov     al,08h
out     dx,al         ;device 8
mov     dx,2eh
mov     al,0f6h         ;device 8, CRF6
out     dx,al
mov     dx,2fh
mov     al,0fh
out     dx,al

;-----
; Exit extend function mode
;-----

mov     dx,2eh
mov     al,0aah
out     dx,al

.exit
end

```

ADLINK also provides watchdog programs and subroutines for easy use under DOS, Windows 95/98/2000, and Windows NT. Please browse ADLINK CD for more information.

4

Intel 815 Chipset Hardware and VGA Driver

This chapter describes the installation procedure of Intel 815 chipset Device Driver for Windows 95/98/2000.

4.1 Hardware Configuration File Installation

This section describes system requirements of Intel 815 chipset Device Driver. This driver has been designed for and tested with Windows 98/95.

The system must contain a supported Intel processor and chipset configuration. Ensure that a mouse is connected to the system. One of the following versions of Windows 95/98/2000 must be installed on the system prior to running utility program.

- Windows 2000 5.00.2195 (Original release)
- Windows 98 Second Edition 4.10.2222 (Original Release)
- Windows 98 4.10.1998 (Original Release)
- Windows 95 4.00.950c (OSR 2.5 with or without USB Supplement)
- Windows 95 4.00.950b (OSR 2.1 with USB Supplement)
- Windows 95 4.00.950b (OSR 2.1 with USB Supplement)
- Windows 95 4.00.950a (OSR1)
- Windows 95 4.00.950 (Original Release)

Installing Hardware Configuration File

This subsection describes how to install the hardware configuration file on a system where Windows 98/95 is installed.

Note: Record the location of the Windows 95/98/2000 directory before installing the driver.

1. Check the System Requirements. Windows 95/98/2000 must be fully installed and running on the system prior to running this software.
2. Close any running applications.
3. The files are stored in an integrated application setup program. This program is designed for a Windows 95/98/2000 program that allows the INF files to be installed.
4. In X:\CHIPDRV\Chipset\I815\Win9x2k\Disk1, and then Run SETUP.EXE.
5. Click 'Next' on Welcome Screen to read and agree to the license agreement. Click **Yes** if you agree to continue. NOTE: If you click **No**, the program will terminate.
6. Click '**Finish**' to restart the system when prompted to do so.
7. Follow the screen instructions and use default settings to complete the setup when Windows 95/98/2000 is re-started. Upon re-start, Windows 95/98/2000 will display that it has found many hardware and is installing driver for them. If one **New Hardware Found** dialog box is displayed requesting the location of the drivers, use the mouse to click on the scrollbar and click on the <Windows 95/98/2000 directory>.
8. Select **Yes**, when prompted to re-start Windows 95/98/2000.

4.2 VGA Driver Installation

This section provides information on how to install the VGA driver that come in the Compact Disk with the package. Please follow the instructions set forth in this section carefully. Please note that there must be relevant software installed in your system before you could proceed to install the VGA driver.

Installing the Drivers for Windows 98/95 and Win 2000

The following section describes the normal display driver installation procedures for Windows 95/98/2000. Use the following procedures when installing the display drivers for Windows 98/95.

1. The driver is included in the ADLINK CD. Run the **win9xm62.exe** (or **win2km62.exe** for Win2000 installation) under the following directory: **X:\CHIPDRV\VGA\815\w9xme** (or **W2K** folder for Win 2000 installation).
2. Click **Next** on **Welcome Screen** to read and agree to the license agreement.
3. Click **Yes** if you agree to continue. NOTE: If you click **No**, the program will terminate.
4. Click **Yes** to restart your computer and for the new settings to take effect.
5. Follow the screen instructions and use default settings to complete the setup when Windows 95/98/2000 is re-started.

Installing the Drivers for Windows NT 4.0

[IMPORTANT]: You should install the Windows NT 4.0 with at least Service Pack 4 (version number: 4.00.1381) first before installing the VGA driver. If you don't have the Windows NT 4.0 Service Pack 4, please contact your software vendor or download it from Microsoft's web site.

The procedures below show you how to install the VG A driver for Windows NT 4.0.

1. Boot Windows NT 4.0.
2. The driver is included in the ADLINK CD. Run the **winnt4m62.exe** under the following directory: **X:\CHIPDRV\VGA\815\nt40**.
3. Click **Next** on **Welcome Screen** to read and agree to the license agreement.

4. Click **Yes** if you agree to continue. NOTE: If you click **No**, the program will terminate.
5. Windows NT 4.0 will prompt you to restart computer. Click **Yes** for the new settings to take effect.
6. Follow the screen instructions and use default settings to complete the setup when Windows NT 4.0 is re-started.



LAN Driver Installation

This chapter describes LAN driver installation for the onboard Ethernet controller *Intel 82562EM* and *Intel 82559*. The relative drivers are under the following ADLINK CD directory: *X:\CHIPDRV\LAN\82559*, where X: is the location of the CD-ROM drive.

5.1 Software and Drivers Support

The Intel LAN drivers support the following OS or platforms:

Windows 98, Windows 95, Windows 2000, Windows NT

Novell Netware, DOS Setup for Novell NetWare DOS

UNIX, OS2, Linux

All the above drivers are included in the ADLINK CD. In the following section, we will describe the driver installation for Windows 98, Windows 2000, and Windows NT. For the driver installation of the other OS, please refer the readme file inside the CD.

5.2 Driver Installation on Windows 2000

The Windows 2000 may install the LAN driver. We recommend you to manually installed the most updated LAN driver, which shipped with ADLINK CD to guarantee the compatibility. After installing the Windows 2000, please update the new drivers by the following procedures.

1. Boot Windows 2000, Click **Start**. Select **Settings** then double-click the **Control Panel**.
2. Double-click **System** icon, click **Hardware** tab, click **Device Manager** button.
3. Double-click Network Adapters entry, Double-click the Intel 8255x-based PCI Ethernet Adapter (10/100) entry.
4. Click **Driver** tab, then click **Update Driver...** button.
5. An Upgrade Device Driver Wizard windows, click **Next>**.
6. Select **Display a list of ...** and click **Next>**. The next window may show a list of hardware models.
7. Insert the CD and click **Have Disk**.
8. Browse the 8255P driver in the following path: **X:\CHIPDRV\LAN\82559**, highlight **oemsetup.inf**, click **Open**, then click **OK**.
9. Highlight the model: **Intel 8255x- based PCI Ethernet Adapter (10/100)**, then click **NEXT>**. An Update Driver Warning window may pop up, click **yes** to continue.
10. Click **NEXT>** button, then the Wizard summary window appears.
11. Click **Finish** button, then click **CLOSE** button.

5.3 Driver Installation on Windows 98

The Windows 98 will install the LAN driver automatically. We recommend you to manually update the LAN, which on the ADLINK CD to guarantee the compatibility. After installing Windows 98, please update the new drivers by the following procedures.

1. Boot Windows 98, Click **Start**. Select **Settings** then double-click the **Control Panel**.
2. Double-click on the **System** icon, click on the **Device Manager** tab.
3. Double-click on the **Network Adapters** entry, select the Intel **8255x-based PCI Ethernet Adapter (10/100)** entry. Click the **Properties** button.
4. Click on the **Driver** button, then click **Update Driver...** button.
5. Update Device Driver Wizard starts, click **NEXT**.
6. Select **Display a list of ...** and click **NEXT**. The next window allows the user to specify a specific path. Insert the CD and click **Have Disk**.
7. **Browse** the 82559 driver in the following path: **X:\CHIPDRV\LAN\82559**, highlight **Oemsetup.inf**, click **OK**. The Update Wizard displays the message that it has found the driver. Click **OK** again to update the driver. Note: Windows 98 may ask you to insert the original Windows 98 CD to install the LAN protocols.
8. Click **NEXT** button, then the Wizard summary window appears.
9. Click **Finish** button, then restart the computer to active the new driver.

5.4 Driver Installation on Windows NT

Windows NT may ask to install a LAN driver from its own library of drivers. We recommend you to manually update the LAN, which on the ADLINK CD to guarantee the compatibility. After installing Windows 98, please update the new driver by the following procedures.

1. From the **Control Panel**, double-click the **Netwok** icon, a Network Configuration window pop up, click **Yes**.
2. In Network Setup Wizard, click **Next>**, click **Select From List...** button.
3. Insert LAN driver floppy diskette into A drive and click **Have Disk**.
4. In the dialog box of Insert Disk window, type in **X:\CHIPDRV\LAN\82559**, Click **OK**.
5. A Select OEM Option window pop up, click **OK**, then click **Next>**.
6. Select necessary Network Protocols, click **Next>**.
7. Select necessary Network Services, click **Next>**.
8. Click **Next>** until Window NT Setup dialog box pop up. Type in **X:\V386** in the dialog box, then insert the original Windows NT CD, and click **Continue**.
9. Then click **OK** until the setup completed.

CSI Drivers Instal

Product Warranty/Service

ADLINK warrants that equipment furnished will be free from defects in material and workmanship for a period of one year from the date of shipment. during the warranty period, we shall, at our option, either repair or replace any product that proves to be defective under normal operation.

This warranty shall not apply to equipment that has been previously repaired or altered outside our plant in any way as to, in the judgment of the manufacturer, affect its reliability. Nor will it apply if the equipment has been used in a manner exceeding its specifications or if the serial number has been removed.

ADLINK does not assume any liability for consequential damages as a result from our product uses, and in any event our liability shall not exceed the original selling price of the equipment. The remedies provided herein are the customer's sole and exclusive remedies. In no event shall ADLINK be liable for direct, indirect, special or consequential damages whether based on contract of any other legal theory.

The equipment must be returned postage-prepaid. Package it securely and insure it. You will be charged for parts and labor if the warranty period is expired or the product is proves to be misuse, abuse or unauthorized repair or modification.