

Embedded Platform for Industrial Computing™ (EPIC) Specification

Version 1.00

March 22, 2004

This specification is a combined technical effort by WinSystems, VersaLogic, Octagon Systems, Micro/sys, and Ampro Corporations to define the next generation SBC.

IMPORTANT INFORMATION AND DISCLAIMERS

Ampro, Micro/sys, Octagon Systems, Versallogic and WinSystems (the “Companies”) do not make any warranties with regard to this Embedded Platform for Industrial Computing™ (EPIC) specification (“Specification”) and in particular, neither warrant or represent that this specification nor any products made in conformance with it will work in the intended manner. Nor do the Companies assume responsibility for any errors that the Specification may contain or have any liabilities or obligations for damages including, but not limited to, special, incidental, indirect, punitive, or consequential damages whether arising from or in connection with the use of this specification in any way.

No representation or warranties are made that any product based in whole or part on this Specification will be free from defects or safe for use for its intended purposes. Any person making, using, or selling such product does so at his or her own risk.

The user of this Specification hereby expressly acknowledges that the Specification is provided as is, and that none of the Companies make any representations, extend any warranties of any kind, either express or implied, oral, or written, including any warranty of merchantability or fitness for a particular purpose, or warranty or representation that the Specification or any product or technology utilizing the Specification or any subset of the Specification will be free from any claims of infringement of any intellectual property, including patents, copyright and trade secrets nor do the Companies assume any responsibilities whatsoever with respect to the Specification or such products.

Copyright 2004 © Octagon Systems, Micro/sys, VersaLogic, WinSystems, and Ampro Computer Corporations.

REVISION HISTORY

Revision 1.0 – March 22, 2004

a. Initial Release

CONTENTS

| | | |
|------------|---|---------|
| 1. | INTRODUCTION | Page 5 |
| 2. | REFERENCE DOCUMENTS | Page 6 |
| 3. | DIMENSIONS AND MOUNTING HOLES | Page 7 |
| 3.1 | Horizontal Dimensions | Page 7 |
| 3.2 | Mounting Holes | Page 7 |
| 3.3 | PC/104 Stack Location | Page 8 |
| 4. | I/O AND VERTICAL CLEARANCE ZONES | Page 8 |
| 4.1 | Zone 1 | Page 8 |
| 4.11 | Zone 1A | Page 9 |
| 4.12 | Zone 1B | Page 9 |
| 4.2 | Zone 2 | Page 9 |
| 4.3 | Zone 3 | Page 9 |
| 4.4 | Tall CPU and Power Zone | Page 9 |
| 4.5 | PC/104 I/O Zone | Page 9 |
| 4.6 | Height Restriction under the PC/104 stack | Page 10 |
| 5. | PCI Express AND FUTURE FABRICS | Page 10 |
| Appendix A | Power Connector Example | Page 11 |
| A.1 | 10-pin ATX-type Power Connector | Page 11 |
| A.2 | 5-pin Screw Terminal Connector | Page 12 |

EPIC SPECIFICATION

Revision 1.00 - March 22, 2004

1. INTRODUCTION

The purpose of this document is to define a physical platform for embedded Single Board Computers with multiple I/O expansion options. Its size is midway between the industry standard PC/104 module and EBX board. This size board will support advanced processors plus complex I/O functions for applications involving data acquisition, video processing, telecommunications, networking, motion control plus the associated field wiring termination, I/O circuit protection, etc. The initial specification defines PC/104 expansion; however, future updates will embrace PCI Express and/or other fabrics.

The key features of the platform are:

1. A board that is a small, industrial-grade, embedded SBC with the option of I/O expansion via PC/104, PC/104-*Plus*, USB, Ethernet, etc.
2. A board that is complementary to EBX and PC/104.
3. A board that will emphasize I/O connector area.
4. A board based upon open industry standards that could be administered by an independent technical standards body.
5. A board that can bridge from current technology into the future. That means that it would be able to support PCI Express, ExpressCard, and other technologies, as they become available and supported in the embedded systems domain.

Designers are always striving to add more functionality in less space. Advances in semiconductor density, packaging technology, and connector technology have made this possible. PC/104 and PC/104-*Plus* are recognized standards as well as EBX; however, there is no industry standard for a mid-size board.

A PC/104 module has 13.4 square inches of area. Included in this area is a PC/104 and PC/104-*Plus* connector. Together, they can take up to 15% of the available board area. It is a challenge to place a CPU and I/O on a board of this size. An EBX board has 46 square inches of area. This allows larger, more powerful processors with cooling fans to be supported in a much larger size board.

This specification defines a new standard, open-architecture, embedded platform that is larger than a 3.550- x 3.775-inch (90mm x 96mm) PC/104 board yet smaller than a 5.75- x 8.0-inch (146mm x 203mm) EBX board. The midpoint between EBX and PC/104 is 29.7 square inches. The 4.5- x 6.5-inch EPIC board's area is 29.25 square inches. The chart on the next page compares the size of these three boards.

Chart 1: Comparison of PC/104, EPIC and EBX physical size

| <u>Relative Size</u> | <u>Name</u> | <u>Dimensions</u> | <u>Board Area</u> |
|----------------------|-------------|--------------------------------|-------------------|
| Small | PC/104 | 3.550 x 3.775-in. (90 x 96 mm) | 13.4 sq. in. |
| Medium | EPIC | 4.5- x 6.5-in. (115 x 165 mm) | 29.25 sq. in. |
| Large | EBX | 5.75- x 8.0-in. (146 x 203 mm) | 46 sq. in. |

2. REFERENCE DOCUMENTS

This document specifies the mechanical information for EPIC. For the most current electrical and mechanical information concerning the PC/104, PC/104-*Plus*, EBX, PCI and PCI Express, contact the references below.

For information about PC/104, PC/104-*Plus*, and EBX

PC/104 Embedded Consortium
PO Box 78008
San Francisco, CA 94107-8008

Phone: 415-243-2104
Fax: 415-836-9094
Email: info@pc104.org
Website: pc104.org

For information about PCI and PCI Express

PCI Special Interest Group
5440 SW Westgate, #217
Portland, OR 97221
Phone: 503-291-2569
Fax: 503-297-1090
Email: administration@pcisig.com
Website: www.pcisig.com

For more information and updates about the EPIC specification,

Website: www.epic-sbc.com

If errors are found in this document, please send your written comments to:

Bob Burckle
WinSystems, Inc.
715 Stadium Drive
Arlington, Texas 76011
FAX 817-548-1358
Email: bburckle@winsystems.com

3. DIMENSIONS AND MOUNTING HOLES

3.1 EPIC Board Dimensions

The EPIC board dimensions measure 4.5- x 6.5-inches (115mm x 165mm).

Figure 1 defines the precise location of the overall dimensions (in inches) and corner mounting holes of the board plus the location of the PC/104 stack, connector placement, and its mounting holes.

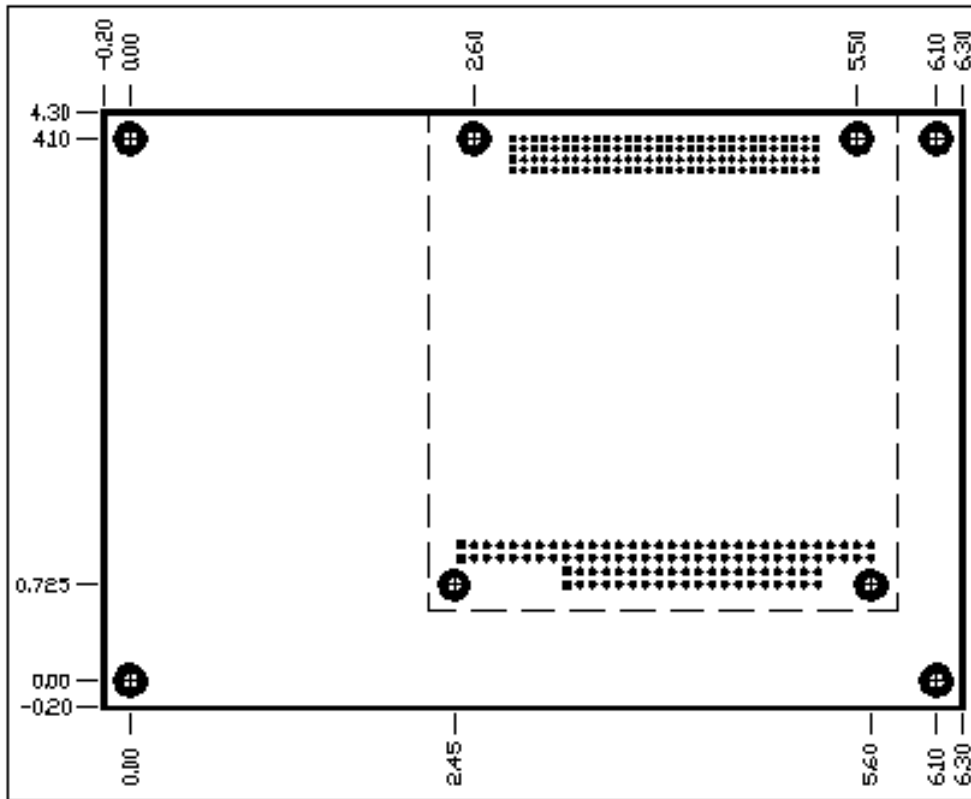

Figure 1: Board Dimensions are 4.5 x 6.5-in. (115mm x 165mm)

3.2 Mounting Holes

Eight mounting holes are specified. Each hole is a 0.125-inch diameter centered inside a 0.250-inch pad. There are 4 mounting holes inset at 0.20-inches on each of the corners of the board plus the four PC/104 mounting holes. It is recommended that all 8 defined holes be used to provide the most rugged attachment of the EPIC board to its mounting bracket, base plate, or enclosure.

3.3 PC/104 Stack Location

The EPIC board provides a PC/104 Bus compatible module stack located in the upper right quadrant of the board. It is inset by 0.5-inches from the right edge to allow for cable access on the EPIC board below.

4. I/O AND VERTICAL CLEARANCE ZONES

The EPIC board is subdivided into 4 zones. These zones are in addition to the area defined for the PC/104 module stack. Certain zones have a specified vertical dimension so as to avoid conflict with an adjacent board or cable assembly.

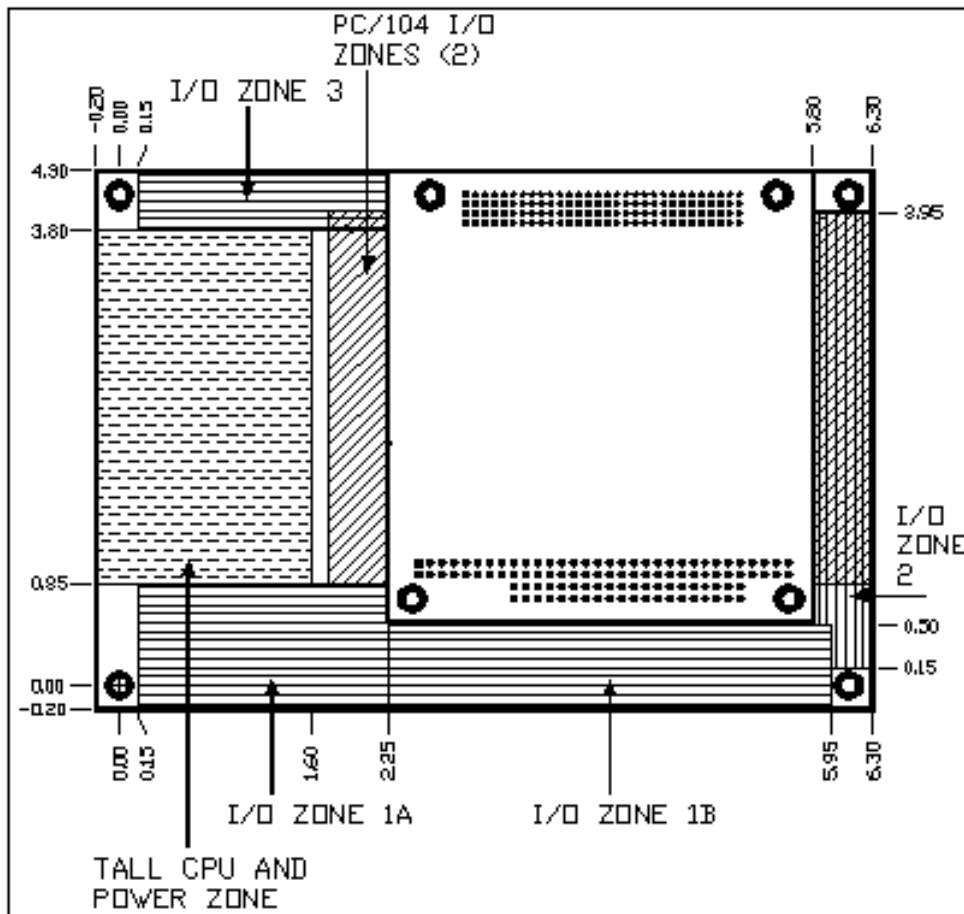

Figure 2: I/O Zones

4.1 Zone 1

Zone 1 is defined for I/O connectors. It is split into Zone 1A and Zone 1B for a total length of 5.8 inches. This zone extends from inside the mounting holes on the bottom of the board.

4.11 Zone 1A

Zone 1A extends for 2.4 inches. Its depth extends to 1.05 inches to allow for deeper connectors such as currently exists for Ethernet, CompactFlash, ExpressCard, and certain stackable molded PC-type connectors.

4.12 Zone 1B

Zone 1B extends for 3.4 inches at a depth of 0.7 inches. It will support industry standard 0.100-inch IDC type connectors, terminal blocks, USB, and other molded PC-type connectors. There is a 0.15- x 0.35-inch overlap with Zone 2.

4.2 Zone 2

Zone 2, located on the right side of the EPIC board, is the second I/O zone. It is specified as 3.8-inches long and 0.5-inches wide. There is a possible height restriction of 0.6-inches if a PC/104 module is plugged into the EPIC board. The first module's cable or connector will be above Zone 2.

4.3 Zone 3

Zone 3 extends for 2.4-inches. Its depth is specified as 0.5-inches. There is a 0.15- x 0.35-inch overlap with the PC/104 I/O Zone if a module is plugged into the stack and if there is a connector in this area.

4.4 Tall CPU and Power Zone

An area of 1.8 x 2.95-inches defines the Tall CPU and Power Zone. More powerful processors typically require a fan and/or heatsink for proper cooling. This area reserves space for these items as well as the power connector.

For deeply embedded applications, power requirements and connector configurations will differ. Therefore, the location, specific connector, pin-out, and current per pin for power to the EPIC is not defined. However, a recommended robust power connector for PC-type designs is shown in Appendix A.

4.5 PC/104 I/O Zone

The PC/104 and PC/104-*Plus* specification defines two, 0.5-inch I/O zones for mating connectors and cables to both edges of the module.

The orientation of the PC/104-*Plus* connector is the same as on EBX. That means for many PC/104-*Plus* modules, the I/O connectors tend to be on the right side of the board. The I/O connector placement on the module is not imperative, but reduces the potential for interference with the CPU fan/heatsink.

4.6 Height Restriction under the PC/104 Stack.

There is a height restriction of 0.345-inches for components placed under the PC/104 module area. This area is between the PC/104 and PC/104-*Plus* connectors. Refer to the PC/104 or PC/104-*Plus* Specifications for details.

5.0 PCI Express and Future Fabrics

Future revisions of this specification will define how advanced fabric support will be added. As of this writing, it is only in the discussion phase and not ready for integration into this specification. For the latest updates, visit www.epic-sbc.com

APPENDIX A - POWER CONNECTOR

For maximum flexibility in meeting specialized customer needs, the EPIC standard does not define a mandatory power connector, its pin count, or pin definitions. These decisions are at the option of each manufacturer. In most cases, an off-the-shelf connector can provide the ruggedness and economy needed for standard industrial applications.

This Appendix demonstrates two examples of a power connector scheme for an EPIC board. The first is a standard 10-pin rugged power connector that can be used for an embedded PC design. Its power connections are similar to what is used on motherboards. The second example demonstrates using a screw terminal block for systems that need just voltages only and no control signals.

A.1 10-pin ATX-type Power Connector

The recommended practice below is based on the popular P1 connector that is defined by the ATX 2.1 compliant power supply specification. It is available from a number of different manufacturers, has a long-term source of supply, and is available throughout the world. It has been tested for shock and vibration and is proven to work well in harsh environments.

An ATX power connector specifies 20 pins. The example in this Appendix is a 10-pin functional subset of that specification. The pin-out of the original specification was not maintained so as to limit the connector size and cost.

Two signals not supported in this recommended practice for an EPIC power connector are -5V and PWR_OK. The -5V is a legacy voltage rarely used in embedded systems. Power OK is a “power good” signal that already exists on virtually all embedded computers.

The pin descriptions are the same as the ATX standard and there is a correspondence to the ATX wiring colors so that making an adapter cable is simplified. A Molex® Mini-Fit Jr™ dual row 10-pin connector or equivalent is an example of a power connector.

| ATX color | Desc. | Pin# | Pin# | Desc | ATX color | Pin numbering |
|-----------|-------|------|------|-------|-----------|---------------|
| Green | PS_ON | 1 | 6 | +5VSB | Purple | |
| Black | COM | 2 | 7 | +5V | Red | |
| Black | COM | 3 | 8 | +5V | Red | |
| Yellow | +12V | 4 | 9 | -12V | Blue | |
| Orange | +3.3V | 5 | 10 | COM | Black | |

Table A1. 10-pin Main Power Connector for EPIC board.

The table above illustrates the recommendations for various board design possibilities. A designer can choose as few as 4-pins up to as many as 10 depending upon the complexity of the EPIC board design. The pin definitions are progressive and the pin order is recommended to reduce the number of field variations that would lead to confusion. If a connector other than those shown here is used, it is recommended that the pin-out correspond to the Table A1 for the same reason.

Comments:

- 1) Pins 1, 2, 6, & 7 provide a +5V system solution.
- 2) Adding pins 3 & 8 give the same function for high power processors.
- 3) A minimal, non-ATX solution is implemented with pins 3, 4, 8, and 9. Pins 1 & 6 can be added for high power.
- 4) 3.3V is intended to power the PC/104-Plus stack.

Please note that PS-ON is an active low TTL signal that turns on the main rails of all the power supplies. If an EPIC board design does not support this function, then the pin should be tied to ground. If +5VSB is not used to provide standby voltage to power circuits during powered-down state on the power rails, then it can be used as +5V main power in conjunction with pins 7 and 8.

A.2 5-pin Screw Terminal Connector

As an alternative to the ATX-style connector above, the recommended practice below is based on a rugged, removable screw terminal connector. Screw terminals allow power to be connected without the use of specialized crimping tools. Some of the lesser used voltages and signals are deleted in order to reduce the number of combinations. The board header pins are rated for 9A.

The table below illustrates the recommendations for various board design possibilities. The design is progressive and the pin order is recommended to reduce the number of field variations that might cause confusion. If a connector other than those shown here is used, it is recommended that the pin-out correspond to the table below, for the same reason.

The pin descriptions are the same as the ATX standard and there is a correspondence to the ATX wiring colors so that making an adapter cable is simplified.

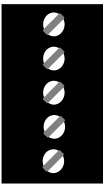
| ATX color | Desc. | Pin# | Pin numbering |
|-----------|-------|----------|--|
| Red | +5V | 1 |  |
| Black | COM | 2 | |
| Yellow | +12V | 3 | |
| Black | COM | 4 | |
| Orange | +3.3V | 5 | |

Table A-2. 5-pin Screw Terminal Connector for EPIC board