



Features

- Intel® Quad or Dual Core™ i7/i5/i3 Processor
- Intel® QM67 Chipset
- Up to 16GB Dual Channel DDR3 SDRAM at 1333MHz
- Three Digital Display Interfaces (DDI) for DisplayPort /HDMI/DVI/SDVO
- Seven PCIe x1, one PCIe x16 (Gen2) for graphics (or general purpose x8/4/1)
- Two SATA 3 Gb/s, two SATA 6 Gb/s, Gigabit LAN, eight USB 2.0

Specifications

Core System

CPU	Sandy Bridge 32 nm process, BGA type Intel® Core™ i7-2715QE 2.1 GHz (3.0 GHz Turbo), 6MB L3 cache, 45W (4C) Intel® Core i7-2655LE 2.2 GHz (2.9 GHz Turbo), 4MB L3 cache, 25W (2C) Intel® Core™ i7-2610UE 1.5 GHz (2.4 GHz Turbo), 4MB L3 cache, 17W (2C) Intel® Core™ i5-2515E 2.5 GHz (3.2 GHz Turbo), 3MB L3 cache, 35W (2C) Intel® Core™ i3-2310E 2.1 GHz, 3MB L3 Cache, 35W (2C) Intel® Core™ i3-2340UE 1.3 GHz, 3MB L3 Cache, 17W (2C) Intel® Celeron® B810E 1.6 GHz, 2MB L3 Cache, 35W (2C) Intel® Celeron® 847E 1.1 GHz, 2MB L3 Cache, 17W (2C)
Memory	Dual channel non-ECC 1066/1333 MHz DDR3 memory up to 16 GB in dual SODIMM socket
Chipset	Intel® Mobile QM67 Express Chipset
L3 Cache	6MB (i7-2715QE), 4MB(i7-2655LE and i7-2610UE), 3MB (i5-2515E)
BIOS	AMI EFI with CMOS backup in 16 Mbit SPI flash
Hardware Monitor	Supply voltages and CPU temperature
Debug Interface	XDP SFF-26 extension for ICE debug
Watchdog Timer	Programmable timer range to generate RESET
Expansion Busses	PCI Express x16 (Gen2) bus for discrete graphics solution or general purpose PCI Express (2 x8 or 1 x8 with 2 x4) 8 PCI Express x1: Lanes 0/1/2/3/4/5/6 are free, lane 7 is occupied by GbE LPC bus, SMBus (system) , I ² C (user)

Video

Integrated in Processor	HD Graphics 3000 at 650–1300 MHz
Integrated Video	DirectX 10.1 and OpenGL 3.0
Feature Support	Intel Clear Video HD Technology Advanced Scheduler 2.0, 1.0, XPDM support DirectX Video Acceleration (DXVA) support for full AVC/VC1/ MPEG2 hardware decode
VGA Interface	Analog VGA support with 300 MHz DAC Analog monitor support up to QXGA (2048 x 1536) and VGA hot plug
LVDS Interface	Dual channel 18/24-bit LVDS
Digital Display Interface	Three DDI ports supporting HDMI / DVT / DisplayPort or SDVO

Audio

Chipset	Integrated on Intel® PCH QM67
Audio Codec	On Express-BASE6 carrier (ALC888)

LAN

Chipset	Intel® Gigabit LAN PHY WG82579LM
Interface	10/100/1000 Mbps Ethernet

Multi I/O

Chipset	Integrated on QM67
USB	Supports up to eight ports USB 2.0
SATA	Supports two SATA ports at 6 Gb/s and two ports at 3 Gb/s with support for RAID 0,1,5,10
SSD	Optional SATA based Solid State Disk 8/16/32 GB

Super I/O

Connected to LPC bus on carrier if needed

TPM

Chipset	Infineon SLB9635TT1.2 (optional)
Type	TPM 1.2

Power Specifications

Input Power	AT mode (12 V +/- 5%) and ATX mode (12 V and 5 Vsb +/- 5%)
Power States	Supports S0, S1, S3, S4, S5
Power Consumption	22 W with Core™ i7-2610UE at 1.5 GHz and 2 GB memory typical
Smart Battery Support	Yes

Mechanical and Environmental

Operating Temp	0°C to 60°C
Storage Temp	-20°C to 80°C
Humidity	90% at 60°C
Shock	15G peak-to-peak, 11ms duration, non-operating
Vibration	Non-operating: 1.88Grms, 5-500Hz, each axis Operating: 0.5Grms, 5-500Hz, each axis
Compatibility	COM Express Type 6, Basic form factor 125mm x 95mm
Certification	CE, FCC, HALT

Operating Systems

Standard Support	Windows® XP(e) / Windows® 7 Linux®
Extended Support (BSP)	Embedded XP support package Linux® 2.6.x BSP VxWorks 6.x AIDI Library for Windows® and Linux®

Functional Diagram

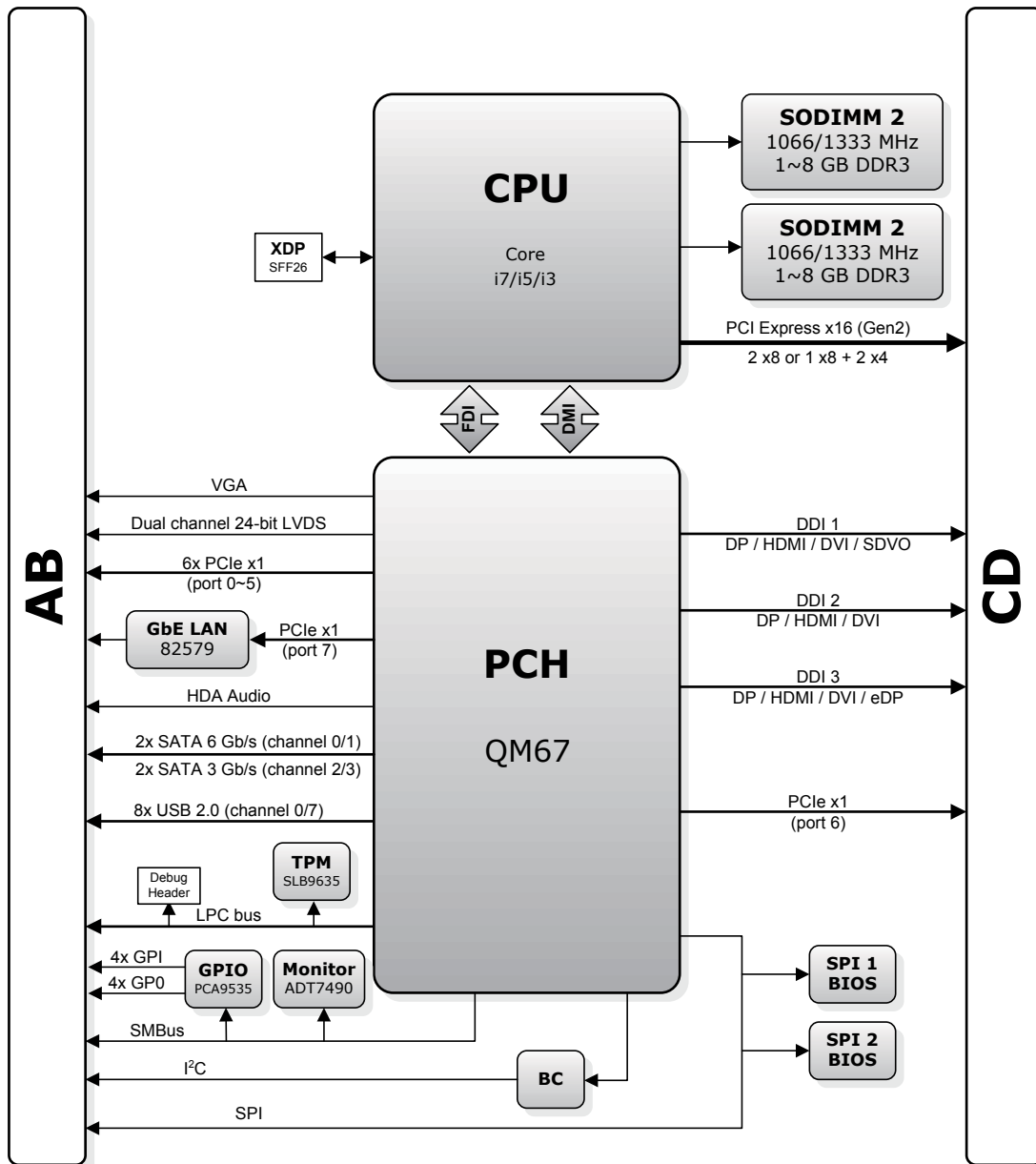

Ordering Information

Modules

Model Number	Description/Configuration
Express-HR-i7-2715QE	COM Express® Type 6 module with 4C Intel® Core i7-2715QE SV processor at 2.1GHz with QM67 chipset
Express-HR-i7-2655LE	COM Express® Type 6 module with 2C Intel® Core i7-2655LE LV processor at 2.2GHz with QM67 chipset
Express-HR-i7-2610UE	COM Express® Type 6 module with 2C Intel® Core i7-2610UE ULV processor at 1.5 GHz with QM67 Chipset
Express-HR-i5-2515E	COM Express® Type 6 module with 2C Intel® Core i5-2515E SV processor at 2.5 GHz with QM67 Chipset
Express-HR-i3-2310E	COM Express® Type 6 module with 2C Intel® Core i3-2310E SV processor at 2.1 GHz with QM67 Chipset
Express-HR-i3-2340UE	COM Express® Type 6 module with 2C Intel® Core i3-2340UE ULV processor at 1.3 GHz with QM67 Chipset
Express-HR-B810E	COM Express® Type 6 module with 2C Intel® Celeron® B810E SV processor at 1.6 GHz with QM67 Chipset
Express-HR-B-847E	COM Express® Type 6 module with 2C Intel® Celeron® B847E ULV processor at 1.1 GHz with QM67 Chipset

Accessories

Model Number	Description/Configuration
Passive Heatsinks	
THSH-HR-BL	High Profile Heatsink for Express-HR with threaded standoffs
Heat Spreaders	
HTS-HR-B	Heatspreader for Express-HR with threaded standoffs
Heatsink with Active Cooling	
THSF-HR-BL	High Performance Heatsink with Fan for Express-HR with threaded standoffs
THSF-HR-BL-QC	High Performance Heatsink with Fan for Express-HR Quad-Core CPU with threaded standoffs